

**ELECTRONIC CIRCUIT ANALYSIS (ECA)
LABORATORY MANUAL (R19-22046)**

II / IV B.Tech (ECE) : II – SEMESTER



Name of the Student :

Regd. No & Section :

Academic Year :

**DEPARTMENT OF ELECTRONICS AND COMMUNICATION
ENGINEERING**

**SIR C. R. REDDY COLLEGE OF ENGINEERING
ELURU – 534 007**

ELECTRONIC CIRCUIT ANALYSIS (ECA) - LAB

II / IV B.Tech (ECE) : II – SEMESTER (R19-22046)

LIST OF EXPERIMENTS

S. NO	NAME OF THE EXPERIMEN	Page Nos
<i>Part - A: Hardware</i>		
1	DETERMINATION OF f_T OF GIVEN TRANSISTOR	5
2	VOLTAGE SERIES FEEDBACK AMPLIFIER	11
3	CURRENT SERIES FEEDBACK AMPLIFIER	17
4	WIEN BRIDGE OSCILLATOR	27
5	RC-PHASE SHIFT OSCILLATOR	33
6	COLPITTS OSCILLATOR	39
7	HARTLEY OSCILLATOR	47
8	TWO STAGE RC-COUPLED AMPLIFIER	55
9	SINGLE TUNED VOLTAGE AMPLIFIER	63
10	DARLINGTON PAIR AMPLIFIER	71
<i>Part – B: Simulation</i>		
1	DETERMINATION OF f_T OF GIVEN TRANSISTOR	9
2	VOLTAGE SERIES FEEDBACK AMPLIFIER	15
3	CURRENT SERIES FEEDBACK AMPLIFIER	21
4	WIEN BRIDGE OSCILLATOR	31
5	RC-PHASE SHIFT OSCILLATOR	35
6	COLPITTS OSCILLATOR	43
7	HARTLEY OSCILLATOR	51
8	TWO STAGE RC-COUPLED AMPLIFIER	59
9	SINGLE TUNED VOLTAGE AMPLIFIER	67
10	DARLINGTON PAIR AMPLIFIER	75
Additional Experiments		
1	SERIES FED CLASS-A POWER AMPLIFIER	77
2	CLASS-B PUSH PULL AMPLIFIER	85
3	COMPLEMENTARY-SYMMETRY CLASS-B POWER AMPLIFIER	91
4	BOOTSTRAP EMITTER FOLLOWER	97

**JAWAHARLAL NEHRU TECHNOLOGICAL
UNIVERSITY: KAKINADA
KAKINADA - 533 003, Andhra Pradesh, India**

ELECTRONICS AND COMMUNICATION ENGINEERING

(Applicable for batches admitted from 2019-2020)



II Year - II Semester

L	T	P	C
0	0	3	1.5

ELECTRONIC CIRCUIT ANALYSIS LAB

Note: The students are required to design the circuit and perform the simulation using Multisim/ Equivalent Industrial Standard Licensed simulation software tool. Further they are required to verify the result using necessary hardware equipment.

List of Experiments :(Minimum of Ten Experiments has to be performed)

1. Determination of f_T of a given transistor.
2. Voltage-Series Feedback Amplifier
3. Current-Shunt Feedback Amplifier
4. RC Phase Shift/Wien Bridge Oscillator
5. Hartley/Colpitt's Oscillator
6. Two Stage RC Coupled Amplifier
7. Darlington Pair Amplifier
8. Bootstrapped Emitter Follower
9. Class A Series-fed Power Amplifier
10. Transformer-coupled Class A Power Amplifier
11. Class B Push-Pull Power Amplifier
12. Complementary Symmetry Class B Push-Pull Power Amplifier
13. Single Tuned Voltage Amplifier
14. Double Tuned Voltage Amplifier

Equipment required:

Software:

- i. Multisim/ Equivalent Industrial Standard Licensed simulation software tool.
- ii. Computer Systems with required specifications

Hardware:

1. Regulated Power supplies
2. Analog/Digital Storage Oscilloscopes
3. Analog/Digital Function Generators
4. Digital Multimeters
5. Decade Resistance Boxes/Rheostats
6. Decade Capacitance Boxes
7. Ammeters (Analog or Digital)
8. Voltmeters (Analog or Digital)
9. Active & Passive Electronic Components

1a. DETERMINATION OF f_T OF GIVEN TRANSISTOR

Exp. No:

Date:

AIM: To determine the f_T of a given transistor.

APPARATUS REQUIRED:

S. No	Name	Range / Value	Quantity
1	Regulated D.C Power supply	0–30 Volts	1
2	Transistor	BC107	1
3	Resistors	1K Ω	2
4	Resistors	100k Ω , 10K Ω , 4.7K Ω .	Each 1
5	Capacitors	10 μ f	3
6	Potential Meter	--	1
7	Signal Generator	(0 – 1MHz)	1
8	Dual Trace CRO	20MHz	1
9	Bread Board and connecting wires	--	1 Set

CIRCUIT DIAGRAM:

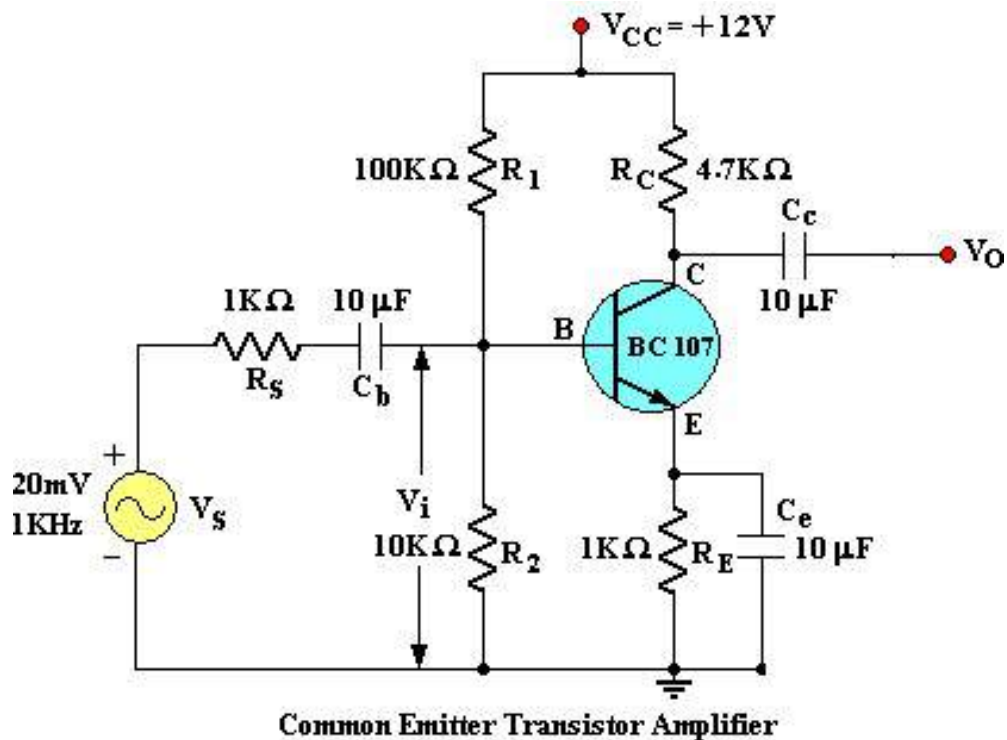

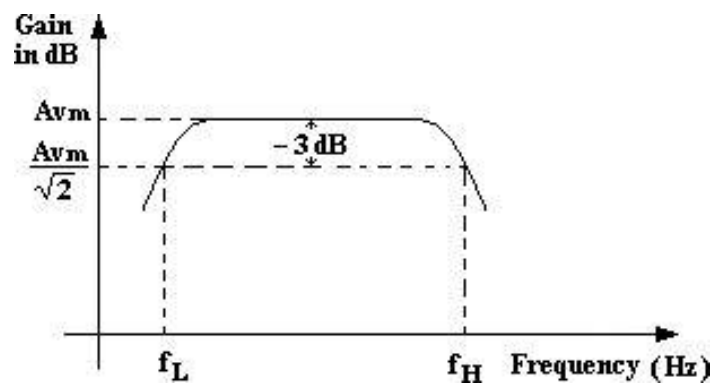
MODEL GRAPH:**THEORY:**

Common Emitter amplifier has the emitter terminal as the common terminal between input and output. The emitter base junction is forward biased and collector base junction is reverse biased, so that transistor remains in active region throughout the operation. When a sinusoidal AC signal is applied at input terminals of circuit during positive half cycle the forward bias of base emitter junction V_{BE} is increased resulting in an increase in I_B , The collector current I_C is increased by β times the increase in I_B , V_{CE} is correspondingly decreased. i.e., output voltage gets decreased. Thus in a CE amplifier a positive going signal is converted into a negative going output signal i.e., 180° phase shift is introduced between output and input signal and it is an amplified version of input signal.

Characteristics of CE amplifier:

1. Large current gain (A_I)
2. Large voltage gain (A_V)
3. Large power gain ($A_P = A_I \cdot A_V$)
4. Phase shift of 180°
5. Moderate input & output impedances.

TABULAR FORM:Input Voltage $V_{in}=10\text{ mV}$

S. No	Frequency (Hz)	Output Voltage (V)	Gain $AV=V_o/V_i$	Gain in dB $20 \log (Av)$
1	100			
2	200			
3	300			
4	400			
5	500			
6	600			
7	700			
8	800			
9	900			
10	1 k			
11	2 k			
12	3 k			
13	4 k			
14	5 k			
15	6 k			
16	7 k			
17	8 k			
18	9 k			
19	10 k			
20	20 k			
21	30 k			
22	40 k			
23	50 k			
24	100 k			
25	200 k			
26	300 k			
27	400 k			
28	500 k			

OBSERVATIONS:

1. Maximum gain (Av) = ----- dB
2. Lower cut-off frequency (F_L) = ----- Hz
3. Upper cut-off frequency (F_H) = ----- MHz
4. Band width (B.W) = ($F_H - F_L$) = ----- kHz
5. Gain bandwidth product $f_T = Av (B.W)$ = ----- Hz.

The voltage gain of the amplifier is given calculate the gain in by $\text{Gain} = 20 \log Av$ Where, V_o is the output voltage. V_s is input voltage of applied AC signal.

PROCEDURE:

1. Connect the circuit as shown in the circuit diagram.
2. Connect the signal generator output to input terminals of the circuit and CH-I of dual trace CRO.
3. Connect the output terminal of the circuit CH-II of the dual trace CRO.
4. Set the power supply voltage to 9V and connect to the circuit.
5. Set the signal generator output sine wave of 100 Hz at 10 mV constant.
6. Vary the function generator frequency from 100 Hz to 500 kHz (as per in the given tabular form) and note the corresponding output voltage.
7. Calculation the gain $AV = V_o/V_i$.
8. PSet the graph frequency verses gain (dB) on a semi log sheet.

RESULT:**VIVA QUESTIONS:**

1. What are the advantages and disadvantages of single-stage amplifiers?
2. Why gain falls at HF and LF?
3. Why the gain remains constant at MF?
4. Explain the function of emitter bypass capacitor, C_e ?
5. How the band width will effect as more number of stages are cascaded?
6. Define frequency response?
7. What is the phase difference between input and output waveforms of a CE amplifier?
8. What is Early effect?
9. Define f_T and give the expression for it?
10. What is meant by Bandwidth of an amplifier?

1b. DETERMINATION OF f_T OF GIVEN TRANSISTOR (Using Simulation)

Exp. No:

Date:

AIM: To determine the f_T of a given transistor using simulation

APPARATUS REQUIRED:

S. No	Name	Range / Value	Quantity
1	Regulated D.C Power supply	0–30 Volts	1
2	Transistor	BC107	1
3	Resistors	1K Ω	2
4	Resistors	100k Ω , 10K Ω , 4.7K Ω .	Each 1
5	Capacitors	10 μ f	3
6	Potential Meter	--	1
7	Signal Generator	(0 – 1MHz)	1
8	Dual Trace CRO	20MHz	1

SIMULATION TOOL:

- Multisim

CIRCUIT DIAGRAM:

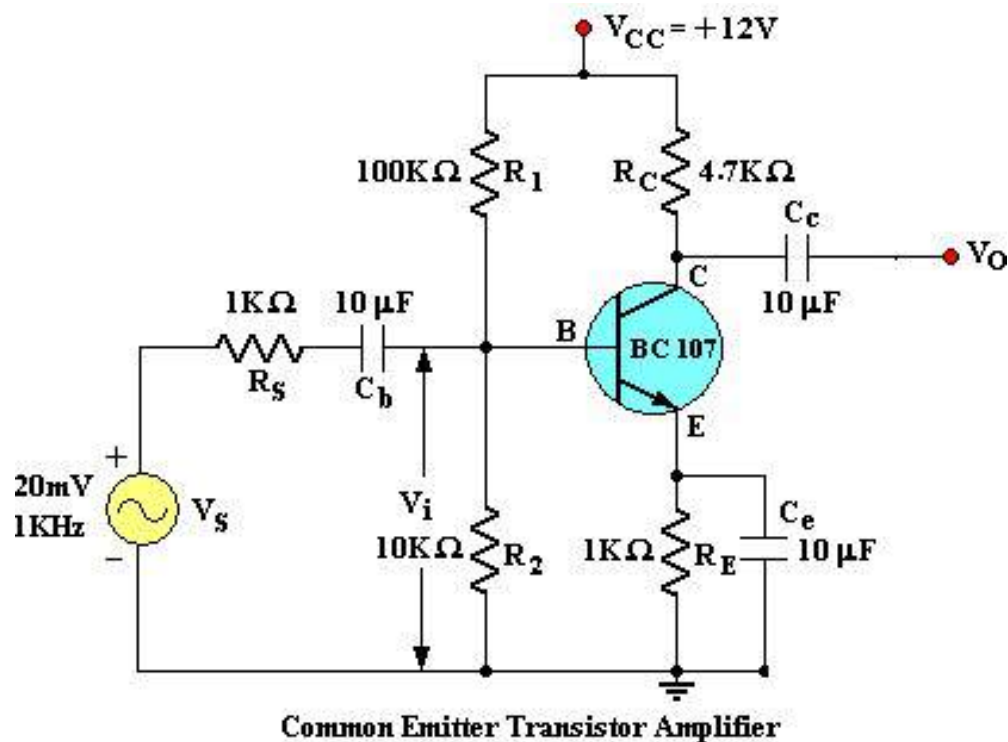

TABULAR FORM:Input Voltage $V_{in}=10\text{ mV}$

S. No	Input Frequency (Hz)	Output Voltage (V)	Gain $AV=V_o/V_i$	Gain in dB $20 \log A_v$
1	100			
2	300			
3	500			
4	700			
5	900			
6	1 k			
7	3 k			
8	5 k			
9	6 k			
10	7 k			
11	9 k			
12	10 k			
13	30 k			
14	50 k			
15	100 k			
16	300 k			
17	500 k			
18	700 k			
19	1M			

OBSERVATIONS:Maximum gain (A_v) = ----- dBLower cut-off frequency (F_L) = ----- HzUpper cut-off frequency (F_H) = ----- MHzBand width (B.W) = ($F_H - F_L$) = ----- kHzGain bandwidth product $f_T = A_v (B.W)$ = ----- Hz.**RESULT:**

2a. VOLTAGE SERIES FEEDBACK AMPLIFIER

Exp. No:

Date:

AIM: To find the gain of the Voltage Series feedback amplifier with & without feedback.

COMPONENTS REQUIRED:

- | | |
|---|--------------|
| 1. Transistor (NPN, Si) BC 107 | : 1 No. |
| 2. Electrolytic Capacitor 10 μ F / 25 V | : 2 Nos. |
| 3. Carbon film Resistors 220 k Ω , 33 k Ω , 100 k Ω , 1 k Ω | : 1 No. each |

MEASURING INSTRUMENTS:

- 20 MHz Dual trace CRO

MISCELLANEOUS:

- | | |
|-------------------------------|----------|
| 1. Trainer Module | : 1 No. |
| 2. 1 MHz Function Generator | : 1 No. |
| 3. 0-30 V 1A D.C power supply | : 1 No. |
| 4. Connecting wires | : 1 Set. |

CIRCUIT DIAGRAM:

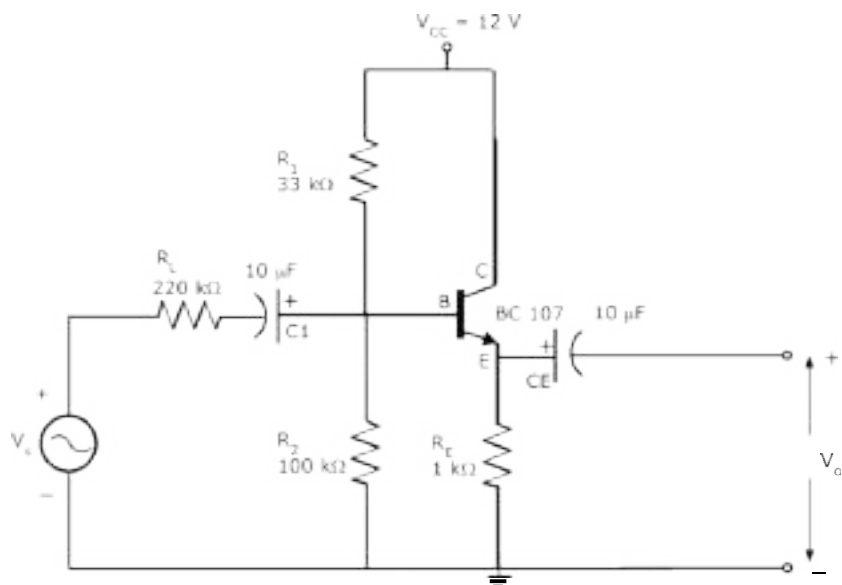

MODEL GRAPH:

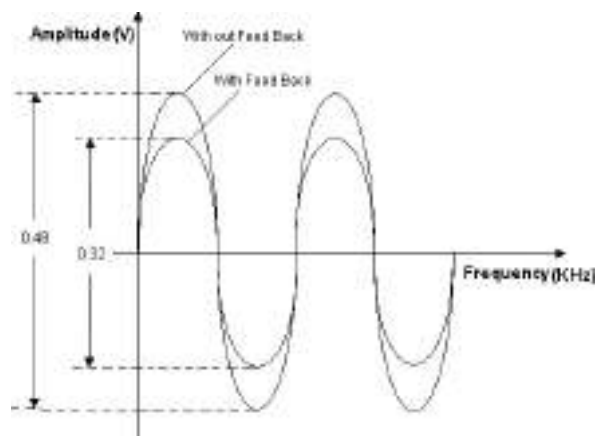

THEORY:

The other name of voltage series feedback amplifier is shunt derived series fed feedback amplifier. The fraction of output voltage is applied in series with input voltage through feedback circuit. Feedback circuit shunt the output but in series with input. So the output impedance is decreased while input impedance is increased. The input & output impedance of an ideal voltage series feedback amplifier is infinite & zero respectively. The resistor R_E is used to provide necessary biasing for the amplifier with voltage series feedback gain of the amplifier decreases.

PROCEDURE:

1. Connect the Circuit as per the circuit diagram.
2. Apply a sine wave of 100 mV peak to peak amplitude at 1 kHz from signal generator to the input of amplifier circuit.
3. Measure the output amplitude V_O (p-p) and Calculate the gain of amplifier without feedback by using $A = V_O/V_S$.
4. Calculate the feedback factor β using $A_F = A / 1+A\beta$.
Calculate theoretically β value from $\beta = R_E / (R_E + R)$.

TABULAR FORM:Input ac voltage $V_S = 100\text{ mV p-p}$ $V_i = \text{ mV}$

S. No.	Input frequency (Hz)	Output voltage (Volts)	Gain $A_v = V_o/V_i$	Gain in dB $20 \log(A_v)$
1	50			
2	100			
3	150			
4	200			
5	500			
6	1 k			
7	3 k			
8	5 k			
9	10 k			
10	30 k			
11	50 k			
12	70 k			
13	100 k			
14	300 k			
15	500 k			
16	600 k			
17	700 k			
18	800 k			
19	900 k			
20	1 M			

RESULT:

VIVA QUESTIONS:

1. Define feedback?
2. Define positive feedback?
3. Define negative feedback?
4. Define sensitivity?
5. What is transfer gain?
6. List out the characteristics of feedback amplifier?
7. What is the effect of input resistance due to series mixing?
8. What happens to output resistance due to voltage sampling?
9. Write the expression for input and output resistance of voltage series feedback amplifier?
10. Give the properties of negative feedback?

2b. VOLTAGE SERIES FEEDBACK AMPLIFIER (Using Simulation)

Exp. No:

Date:

AIM: To find the gain of the Voltage Series feedback amplifier with & without feedback using Simulation.

COMPONENTS REQUIRED:

- | | |
|---|--------------|
| 4. Transistor (NPN, Si) BC 107 | : 1 No. |
| 5. Electrolytic Capacitor 10 μ F / 25 V | : 2 Nos. |
| 6. Carbon film Resistors 220 k Ω , 33 k Ω , 100 k Ω , 1 k Ω | : 1 No. each |

MEASURING INSTRUMENTS:

- 20 MHz Dual trace CRO

MISCELLANEOUS:

- | | |
|-------------------------------|---------|
| 5. Trainer Module | : 1 No. |
| 6. 1 MHz Function Generator | : 1 No. |
| 7. 0-30 V 1A D.C power supply | : 1 No. |

SIMULATION TOOL:

- Multisim

CIRCUIT DIAGRAM:

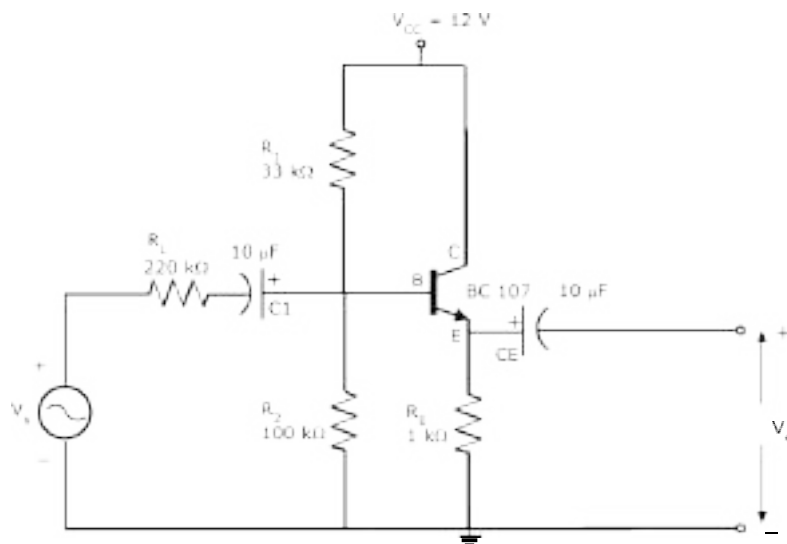

TABULAR FORM:Input ac voltage $V_S = 100 \text{ mV p-p}$ $V_i = \text{ } \text{ mV}$

S. No.	Input frequency (Hz)	Output voltage(V)	Gain $A_V = V_o/V_i$	Gain in dB $20 \log(A_V)$
1	50			
2	100			
3	150			
4	200			
5	500			
6	1 k			
7	3 k			
8	5 k			
9	10 k			
10	30 k			
11	40 k			
12	50 k			
13	60 k			
14	70 k			
15	80 k			
16	90 k			

PROCEDURE:

1. Connect the Circuit as per the circuit diagram.
2. Apply a sine wave of 100 mV peak to peak amplitude at 1 kHz from signal generator to the input of amplifier circuit.
3. Measure the output amplitude V_O (p-p) and Calculate the gain of amplifier without feedback by using $A = V_O/V_S$.
4. Calculate the feedback factor β using $A_F = A / 1 + A\beta$.
5. Calculate theoretically β value from $\beta = R_E / (R_E + R)$.

RESULT:

3a. CURRENT SERIES FEEDBACK AMPLIFIER

Exp. No:

Date:

AIM:

1. To study the current shunt feedback amplifier
2. To measure the voltage gain of the amplifier at 1 KHz.
3. To obtain the frequency response characteristic and the band width of the amplifier.

APPARATUS:

S. No	Name	Range / Value	Quantity
1	Regulated Power Supply	(0– 30V)	1
2	Transistor	BC 107	1
3	Resistors	100K Ω ,4.7K Ω ,10K Ω	Each 1
4	Resistors	1K Ω - 2	1
5	Capacitors	10 μ F – 3	1
6	Function generator	--	1
7	CRO	--	1

CIRCUIT DIAGRAM:

WITHOUT FEEDBACK:

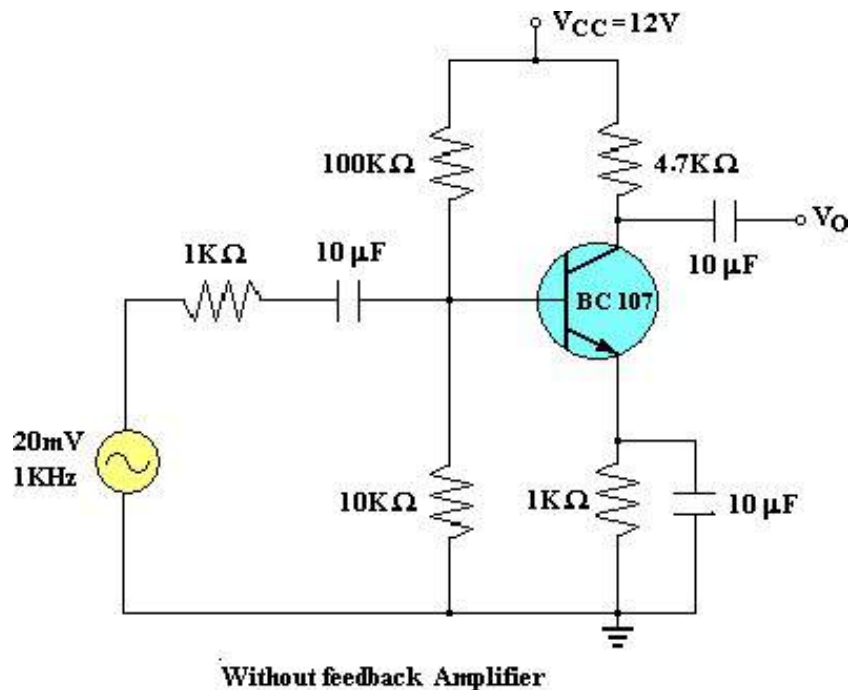

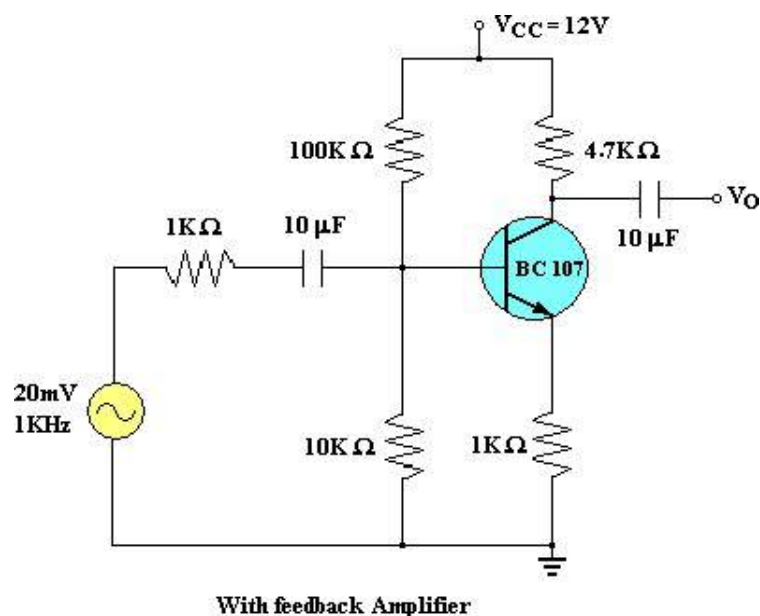
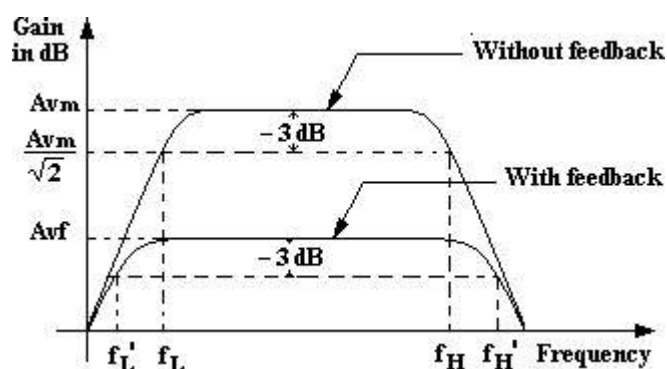
WITH FEEDBACK:**MODEL GRAPH:****THEORY:**

Feedback plays a very important role in electronic circuits and the basic parameters, such as input impedance, output impedance, current and voltage gain and bandwidth, may be altered considerably by the use of feedback for a given amplifier. A portion of the output signal is taken from the output of the amplifier and is combined with the normal input signal and thereby the feedback is accomplished.

There are two types of feedbacks. They are i) Positive feedback and ii) Negative feedback. Negative feedback helps to increase the bandwidth, decrease gain, distortion, and noise, modify input and output resistances as desired. A current shunt feedback amplifier circuit is illustrated in the figure. It is called a series-derived, shunt-fed feedback. The shunt connection at the input reduces the input resistance and the series connection at the output increases the output resistance. This is a true current amplifier.

PROCEDURE:**AMPLIFIER WITHOUT FEED BACK:**

1. Connect the circuit as shown in the figure – 1.
2. Apply a 20 mV sinusoidal signal at a frequency of 100 Hz and observe the I / P signal in the C.R.O.
3. Determine the O / P voltage V_0 using the C.R.O.
4. Determine the gain of the amplifier $A_V = V_0 / V_I$.
5. Now vary the frequency in convenient steps upto 1MHz keeping the I / P constant and for each frequency note down the O / P voltage.
6. Tabulate the readings.
7. Draw a graph between the frequency and the gain in decibels and determine the band width.

AMPLIFIER WITH FEEDBACK:

1. Connect the circuit as shown in the figure – 2.
2. Apply a 20 mV sinusoidal signal at a frequency of 100 Hz and observe the I / P signal in the C.R.O.
3. Determine the O / P voltage V_0 using the C.R.O.
4. Determine the gain of the amplifier with feedback $A_{Vf} = V_0 / V_I$. Compare this gain with the gain of the Amplifier without feedback.
5. Now vary the frequency in convenient steps up to 1MHz keeping the I / P constant and for each frequency note down the O / P voltage.
6. Tabulate the readings.
7. Draw a graph between the frequency and the gain in decibels and determine the band width. Compare the band width with the band width of the Amplifier without feedback.

TABULAR FORM: $V_i = 20\text{mV}$

Frequency (Hz)	Without Feedback			With Feedback		
	V_0 (Volts)	Gain $A_v = V_0/V_i$	Gain in db ($20\log A_v$)	O/P V_0 (Volts)	Gain $A_{vf} = V_0/V_i$	Gain in db ($20\log A_v$)
50						
100						
300						
500						
700						
1K						
3K						
5K						
7K						
10K						
30K						
50K						
70K						
100K						
300K						
500K						
700K						
1M						

RESULT:

Gain of the Amplifier without feedback at 1 kHz is $A_v =$ =

Gain of the Amplifier with feedback at 1 kHz is $A_{vf} =$ =

Band width of the Amplifier without feedback =

Band width of the Amplifier with feedback =

VIVA QUESTIONS:

1. What are the different types of feedback techniques?
2. What is the type of feedback incorporated in oscillators?
3. What are the advantages of negative feedback?
4. Why positive feedback is not used in amplifiers?
5. What is the expression for the desensitivity factor in case of negative feedback?
6. What happens to the band width of an amplifier if we incorporate negative Feedback?

3b. CURRENT SERIES FEEDBACK AMPLIFIER (Using Simulation)

Exp. No:

Date:

AIM: To Set the frequency response curve of an amplifier with and without feedback.

APPARATUS:

S. No	Name	Range / Value	Quantity
1	Regulated Power Supply	(0– 30V)	1
2	Transistor	BC 107	1
3	Resistors	100K Ω , 10K Ω	Each 1
4	Resistors	1K Ω	2
5	Capacitors	10 μ F	3
6	Function generator	--	1
7	CRO	--	1

SIMULATION TOOL:

- Multisim

THEORY:

When any increase in the output signal results into the input in such a way as to cause the decrease in the output signal, the amplifier is said to have negative feedback. The advantages of providing negative feedback are that the transfer gain of the amplifier with feedback can be stabilized against variations in the hybrid parameters the transistor or the parameters of the other active devices used in the circuit. The most advantage of the negative feedback is that by proper use of this, there is significant improvement in the frequency response and in the linearity of the operation of the amplifier.

The main disadvantage of the negative feedback is that the voltage gain is decreased. In Current-Series feedback, the input impedance of the amplifier is increased and the output impedance is also increased. Noise and distortions are reduced considerably.

PROCEDURE:

AMPLIFIER WITHOUT FEEDBACK:

1. Connect the circuit as shown in figure – 1.
2. Apply a 20mV sinusoidal signal at a frequency of 100Hz and observe the I/P waveform in the CRO.
3. Determine the O/P Voltage V_o using the CRO.
4. Determine the gain of the amplifier $A_v = V_o/V_i$.
5. Now vary the frequency in convenient steps up to 1MHz keeping the I/P constant and for each frequency note down the O/P voltage.
6. Tabulate the readings.
7. Draw the graph between the frequency and the gain in decibels and determine the band width.

CIRCUIT DIAGRAM:

WITHOUT FEEDBACK:

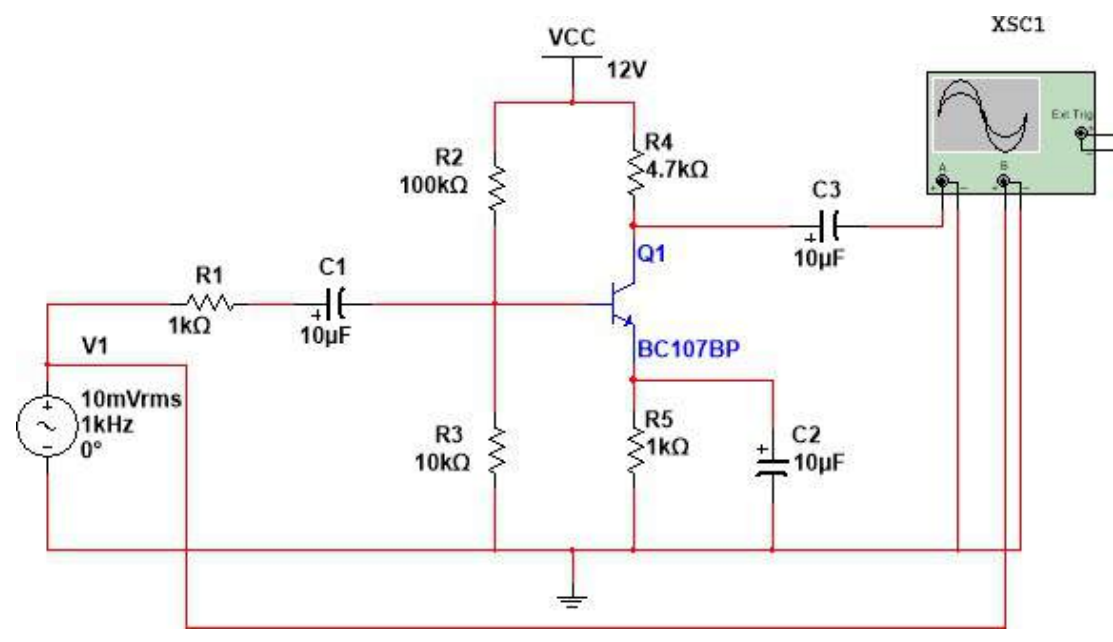

Amplifier without feedback

Input and Output waveforms:

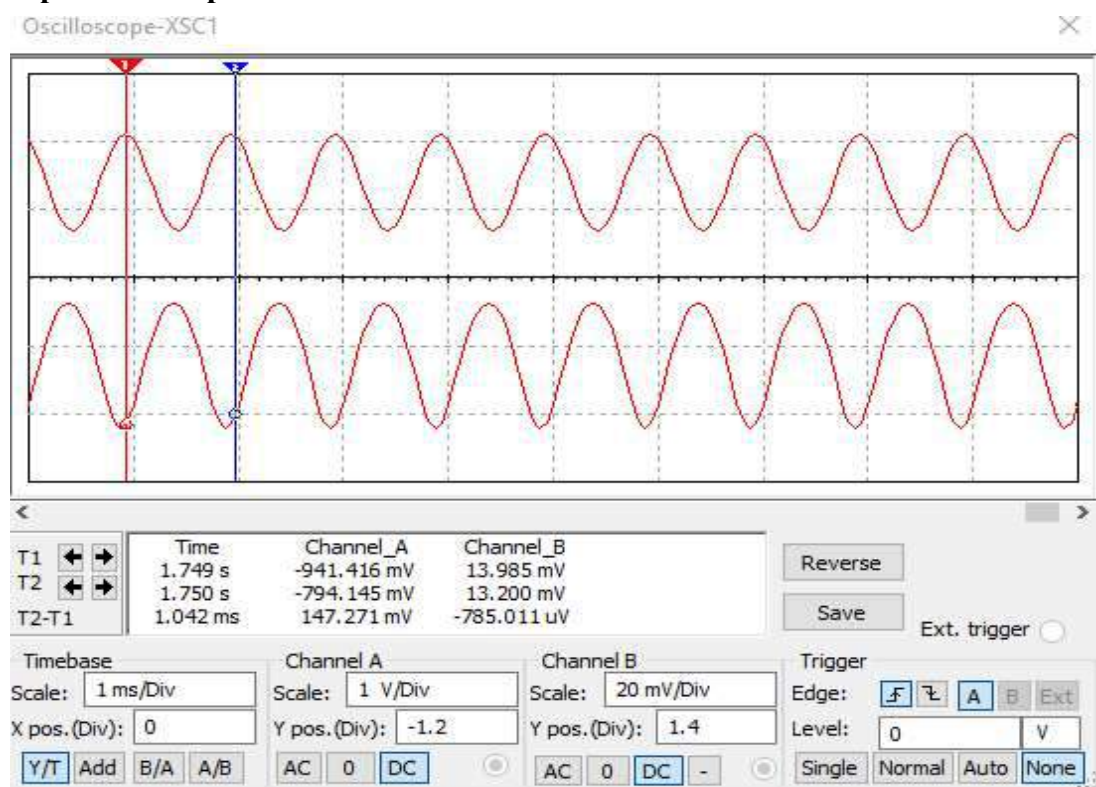

AMPLIFIER WITH FEEDBACK:

1. Connect the circuit as shown in figure – 2.
2. Apply a 20mV sinusoidal signal at a frequency of 100Hz and observe the I/P Waveform in the CRO.
3. Determine the O/P Voltage V_o using the CRO.
4. Determine the gain of the amplifier $A_{vf} = V_o/V_i$. Compare this gain with the gain of the Amplifier without feedback.
5. Now vary the frequency in convenient steps up to 1MHz keeping the I/P constant and for each frequency note down the O/P voltage.
6. Tabulate the readings.
7. Draw the graph between the frequency and the gain in decibels and determine the band width. Compare the band width with the band width of the Amplifier without feedback.

RESULT & DISCUSSION:

Gain of the Amplifier without feed back at $A_v =$

Gain of the Amplifier with feedback at $A_{vf} =$

Band width of the Amplifier without feedback =

Band width of the Amplifier with feedback =

WITH FEEDBACK:

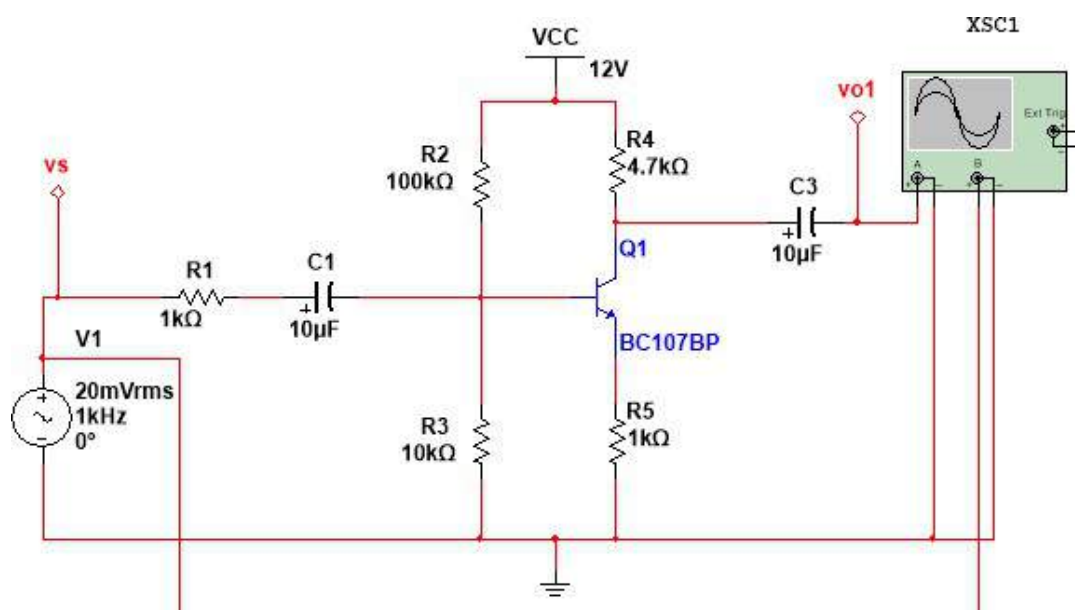

Amplifier with feedback

Input and Output waveforms:

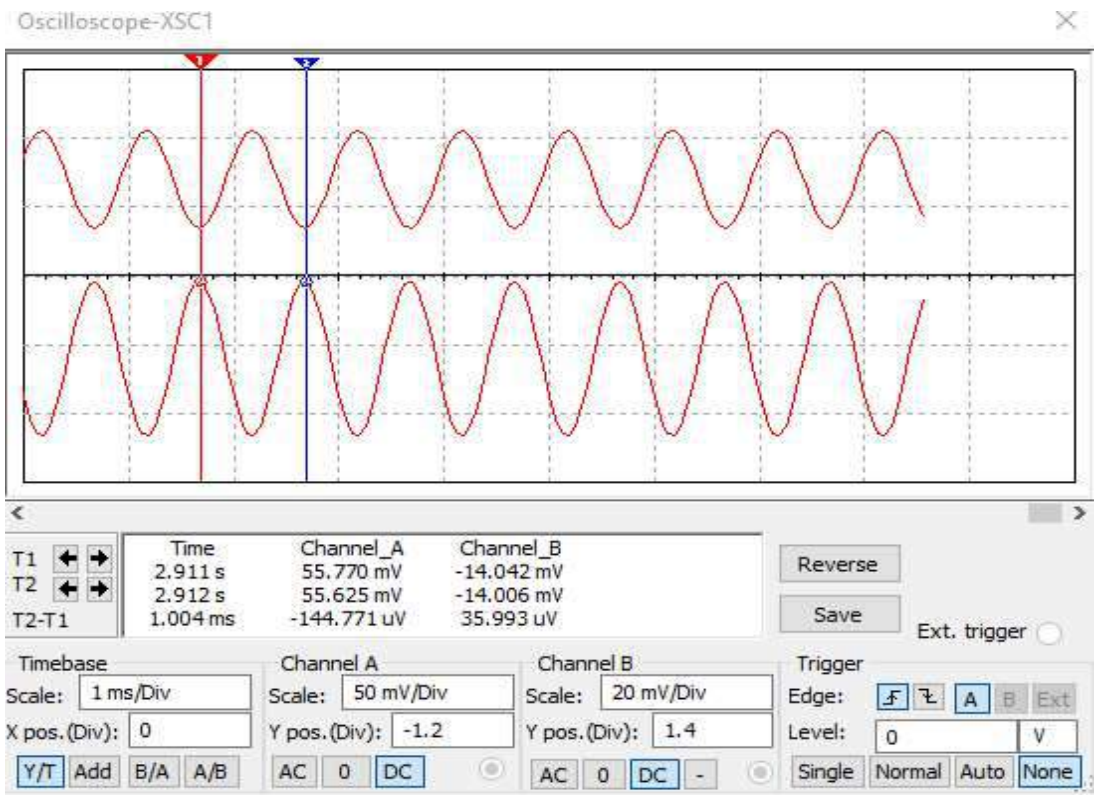

MODEL GRAPH:

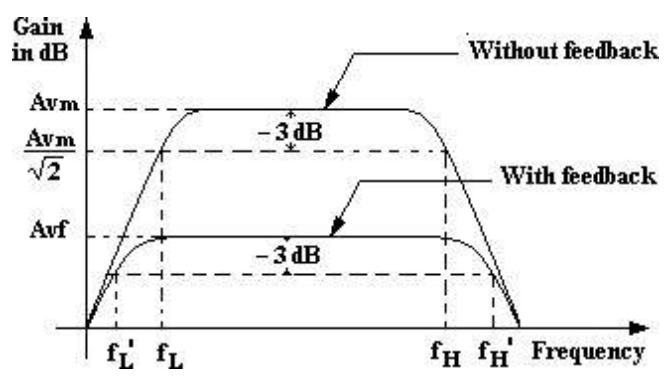

Frequency Response:

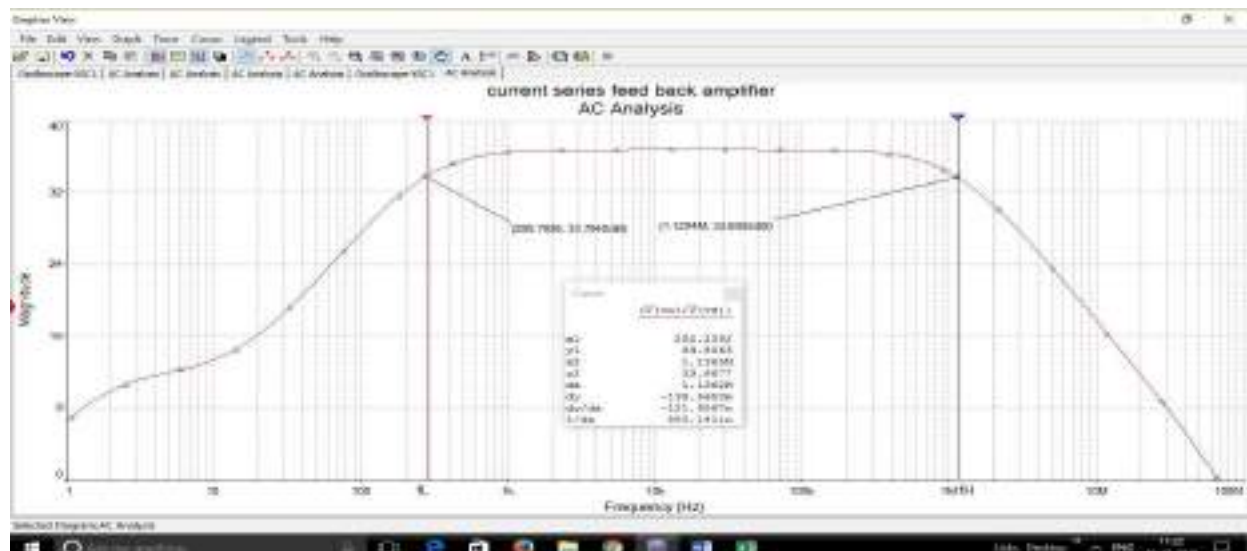

Frequency response without feed back

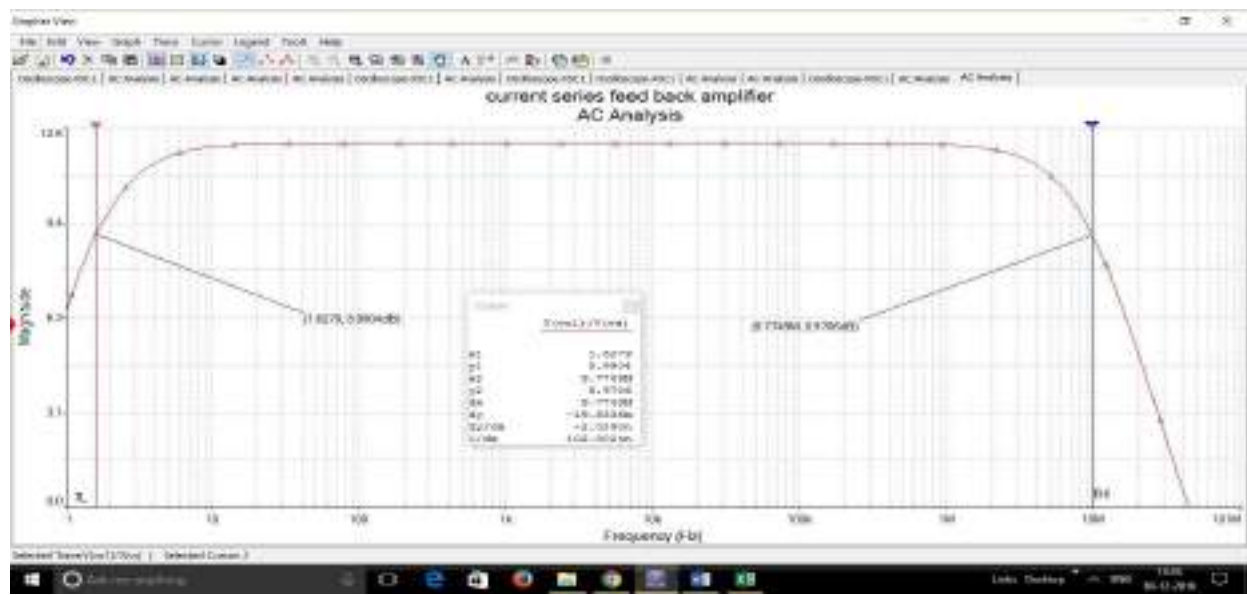

Frequency series response with feed back

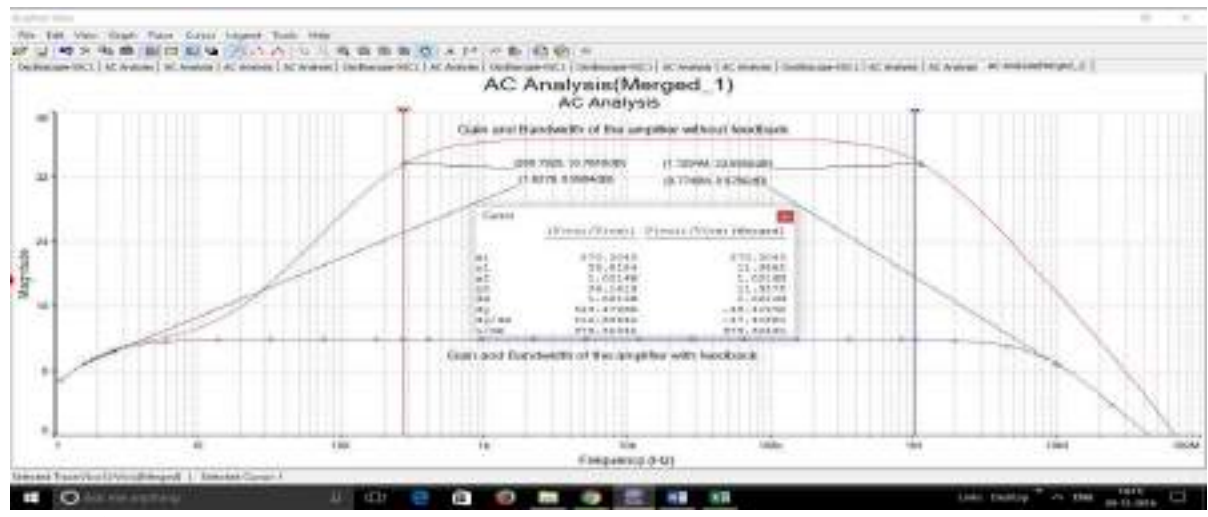

Comparison between Without and With feedbacks in terms of gain and bandwidth

TABULAR FORM:

Frequency (Hz)	Without Feedback			With Feedback		
	V_0 (Volts)	Gain $A_v=V_0/V_i$	Gain in db ($20\log A_v$)	O/P V_0 (Volts)	Gain $A_{vf}=V_0/V_i$	Gain in db ($20\log A_v$)
50						
100						
300						
500						
700						
1K						
3K						
5K						
7K						
10K						
30K						
50K						
70K						
100K						
300K						
500K						
700K						
1MHz						
10 MHz						
100 MHz						

Gain and Bandwidth of Current series feedback amplifier

Max Gain: **3dB Gain:** **B.W. Without feedback:**

Max Gain: **3dB Gain:** **B.W. With Feedback:**

VIVA QUESTIONS:

1. What are the different types of feedback topologies?
2. Which type of feed back incorporated in oscillators?
3. What are the advantages of negative feedback?
4. Why positive feedback is not used in Amplifiers?
5. What is the expression for the de-sensitivity factor in case of negative feed back?
6. What is the effect of negative feed back on band width of an Amplifier?

4a. WIEN BRIDGE OSCILLATOR

Exp. No:

Date:

AIM: To determine the frequency of oscillations of a given Wien Bridge oscillator and compare it with the theoretical value.

APPARATUS:

S. No	Name	Range / Value	Quantity
1	Regulated Power Supply	[- 15V – 0V – +15V]	1
2	OPAMP	μ A741C	1
3	Potentiometer	47 K Ω	1
4	Resistors	3.3 K Ω , 220 Ω	Each 2
5	Resistors	12 K Ω	1
6	Capacitors	0.047 μ F, 0.33 μ F	Each 2
7	CRO.	--	1

CIRCUIT DIAGRAM:

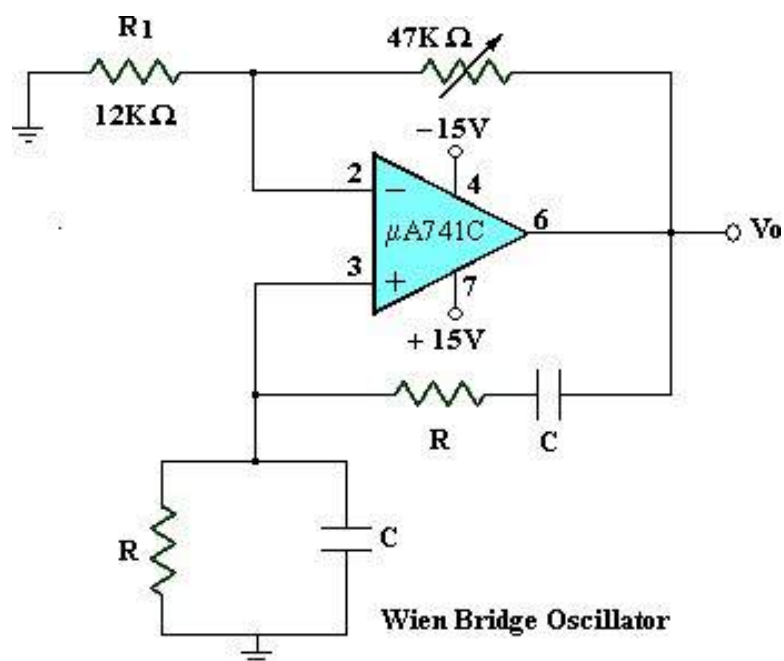

OUT PUT WAVE FORM:

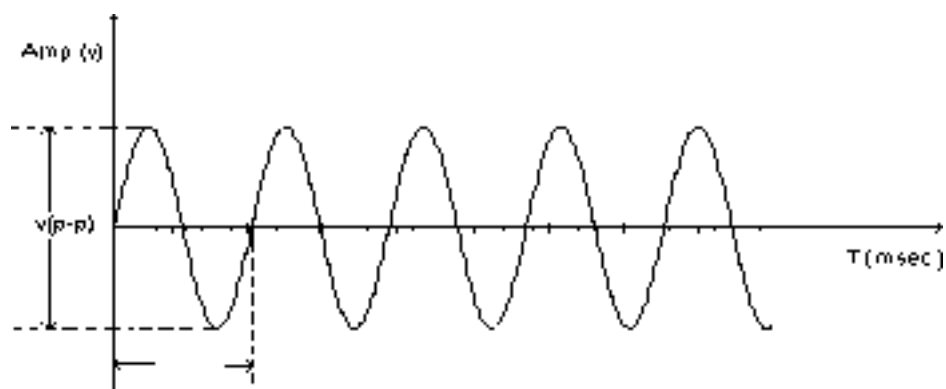

TABULAR FORM:

S.No	Capacitance C (μ F)	Resistance R (Ω)	Theoretical Frequency = 1/(2π RC) (Hz)	Practical Frequency=1/T (Hz)
1	0.047	3.3K		
2	0.33	220		

THEORY

The circuit diagram of Wien bridge oscillator is given in figure .The circuit consists of a two stage RC coupled amplifier which provides a phase shift of 360^0 or 0^0 . A balanced bridged is used as the feedback network which has no need to provide any additional phase shift. The feedback network consists of lead-lag network (R_1-C_1 and R_2-C_2) and a voltage divider. The lead-lag network provides positive feedback to the input of first stage and the voltage divider provides a negative feedback to the emitter of Q1. If the bridge is balanced,

where X_{c1} and X_{c2} are the reactance of the capacitors.

By simplifying and equating the real and imaginary parts on both sides, we get the frequency of oscillation as, the ratio of R_3 to R_4 being greater than 2 will provide a sufficient gain for the circuit to oscillate at the desired frequency. This oscillator is used in commercial audio signal generator.

PROCEDURE:

1. Connect the circuit as shown in the figure.
2. Connect 0.047 μ F, and 3.3 K Ω in place of C and R.
3. Connect the O/P to the C.R.O and observe the sinusoidal signal and measure its frequency.
4. Connect 0.33 μ F, and 220 Ω in places of C and R.
5. Observe the sinusoidal signal and measure its frequency.
6. Tabulate the readings and Compare it with theoretical values

FORMULAS:

$$\text{Practical Frequency} \quad f_o = \frac{1}{T}$$

$$\text{Theoretical Frequency} \quad f_o = \frac{1}{2\pi RC}$$

RESULT:

Theoretical frequency = KHz.
Practical frequency = KHz.

VIVA QUESTIONS:

1. What are the different techniques for the stabilization of an oscillator?
2. What is the principle of operation of Wein Bridge oscillator?
3. What is the condition imposed on R_F and R_1 to get oscillations in case of Wien Bridge oscillator?
4. State barkhausen criterion?
5. What is the condition imposed on A and β to get sustained oscillations?

Extra:

1. Classify oscillators depending on discrete components used
2. What are the differences between oscillators and amplifiers?
3. What did you understand by the term stability of an Oscillator?
4. Which type of feedback used in wein-bridge oscillator?
5. What are the essential parts of an Oscillator?
6. Name two low frequency Oscillators?
7. Name two high frequency Oscillators?
8. What is Barkhausen criterion?
9. What is sustained Oscillation?

CIRCUIT DIAGRAM - 2:

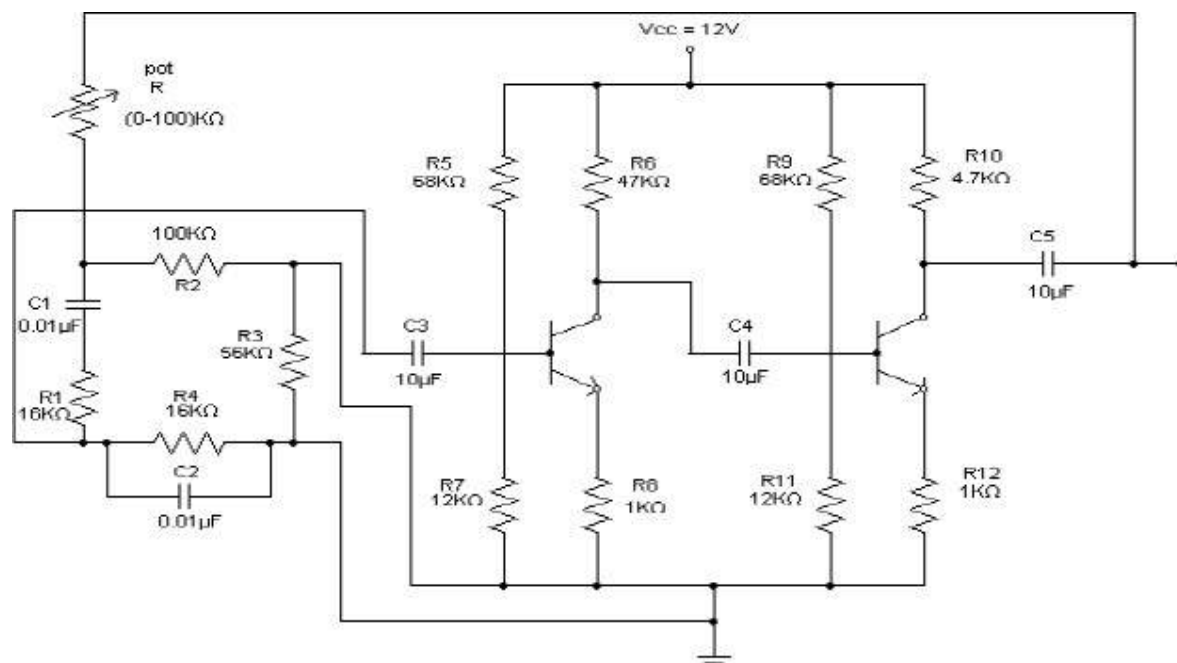

4b. WIEN BRIDGE OSCILLATOR (Using Simulation)

Exp. No:

Date:

AIM: Design and generate a sine wave for different RC values (Wien Bridge oscillator) by using Simulation software.

APPARATUS:

S. No	Name	Range / Value	Quantity
1	Regulated Power Supply	[- 15V – 0V – +15V]	1
2	OPAMP	μ A741C	1
3	Potentiometer	47 K Ω	1
4	Resistors	3.3 K Ω , 220 Ω	Each 2
5	Resistors	12 K Ω	1
6	Capacitors	0.047 μ F, 0.33 μ F	Each 2
7	CRO.	--	1

SIMULATION TOOL:

- Multisim

CIRCUIT DIAGRAM:

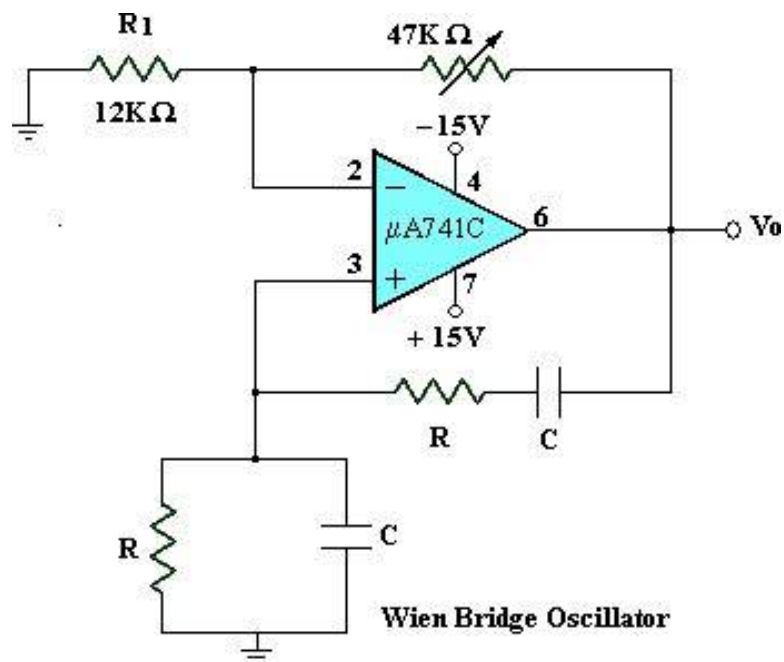

OUT PUT WAVE FORM:

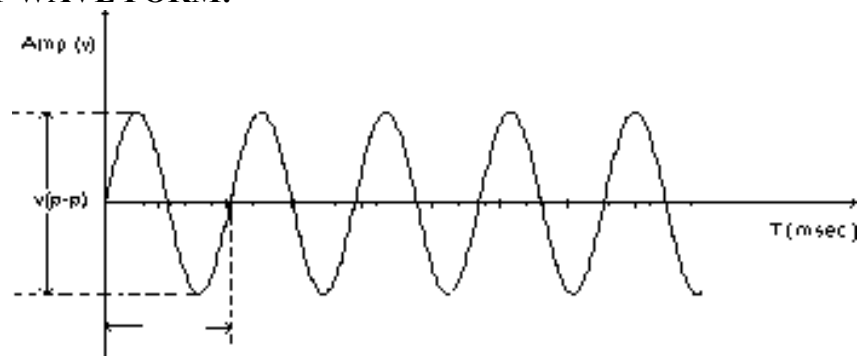

PROCEDURE:

1. Connect the circuit as shown in the circuit diagram.
2. Connect the output terminal of the circuit to Channel – 1 of the dual trace CRO.
3. Simulate, adjust the potentiometer (i.e., 12 kΩ variable resistance) to get the correct sine wave form. Place the both cursers in the CRO observe the T2– T1 as T.
4. PSet the graph for the obtained frequency

OBSERVATIONS:

Frequency of oscillations:

GRAPH:

PSet the observed output on a graph sheet.

RESULT:

CIRCUIT DIAGRAM - 2:

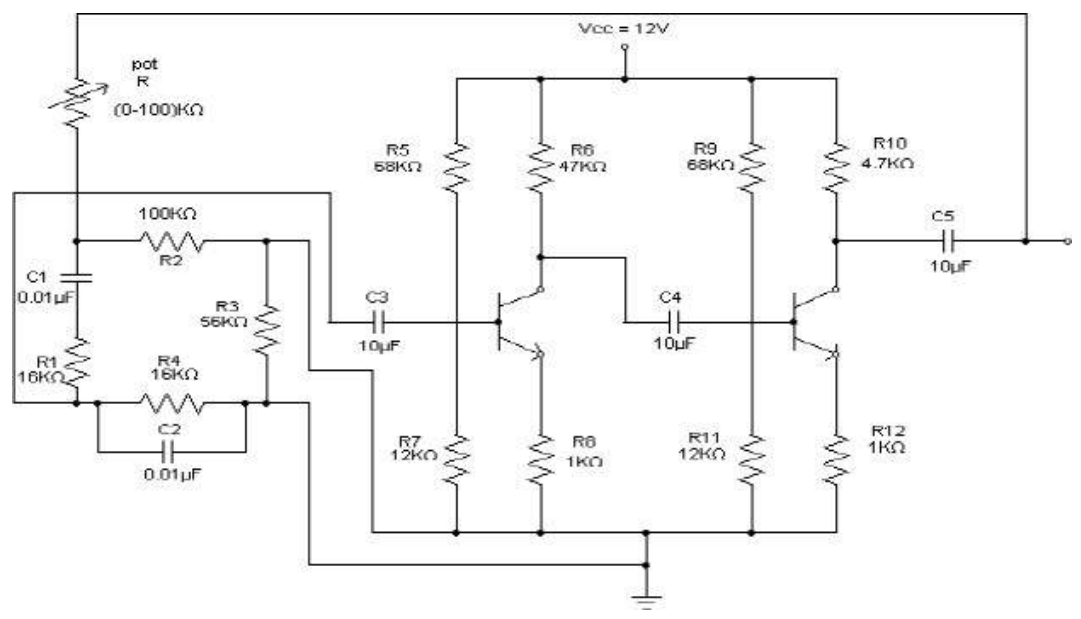

5a. RC-PHASE SHIFT OSCILLATOR

Exp. No:

Date:

AIM : To determine the frequency of oscillations of a given RC phase shift Oscillator.

APPARATUS:

S. No	Name	Range / Value	Quantity
1	DC Regulated power supply	(0 – 30V)	1
2	Transistor	BC 107	1
3	Resistors	1K Ω , 47K Ω , 560 Ω	Each 1
4	Resistors	4.7K Ω	4
5	Capacitors	0.1 μ F, 0.01 μ F, 0.001 μ F	Each 3
6	Capacitors	0.047 μ F	1
7	Capacitors	$\frac{100 \mu F}{20V}$	1

CIRCUIT DIAGRAM:

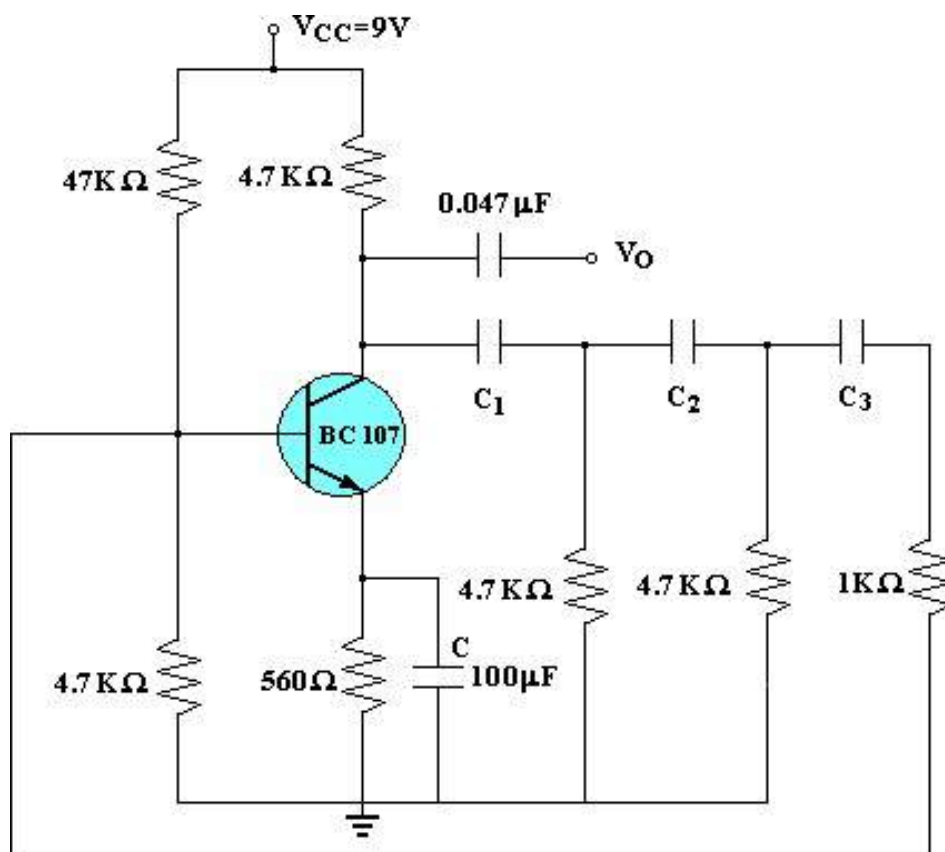

RC-Phase shift Oscillator

PROCEDURE:

1. Connect the circuit diagram as shown in the figure.
2. Switch on the power supply.
3. Connect the O/P terminals to C.R.O.
4. Observe the sinusoidal wave form on C.R.O.
5. Determine the time period (T) of the wave form and frequency (1/T).
6. Repeat the above procedure for different sets of Capacitors.
7. Tabulate the readings and compare with theoretical values.

TABULAR FORM:

S.No	Resistance (KΩ)	Capacitance (μF)	Practical Frequency (Hz)	Theoretical Frequency (Hz)
1	4.7	0.1		
2	4.7	0.01		
3	4.7	0.001		

CALCULATIONS:

$$f(\text{practical}) = 1/T \text{ Hz.}$$

$$f_o = \frac{1}{2\pi RC\sqrt{6+4K}} \text{ (Theoretical)}$$

$$\text{Where } K = R_C / R = 1.$$

$$R_1 = R_2 = R_3 = R.$$

$$C_1 = C_2 = C_3 = C.$$

RESULT:**VIVA QUESTIONS:**

1. Which type of feedback is incorporated in RC phase shift oscillator ?
2. Can we built up an RC phase shift oscillator using two stages of RC network of each 90° phase shift ?
3. State Barkhausen criterion?
4. What is the condition imposed on A and β to get sustained oscillations ?

5b. RC-PHASE SHIFT OSCILLATOR (Using Simulation)

Exp. No:

Date:

PRELAB:

1. Study the different types of oscillator and their necessary conditions.
2. Identify all the formulas required to calculate frequency.

OBJECTIVE:

1. To simulate RC phase shift oscillator in Multisim and study the transient response.
2. To determine the phase shift of RC network in the circuit.

SOFTWARE TOOL:

- Multisim.

APPARATUS:

S. No	Name	Range / Value	Quantity
1	DC Regulated power supply	(0 – 30V)	1
2	Transistor	BC 107	1
3	Resistors	1K Ω , 47K Ω , 560 Ω	Each 1
4	Resistors	4.7K Ω	4
5	Capacitors	0.1 μ F, 0.01 μ F, 0.001 μ F	Each 3
6	Capacitors	0.047 μ F	1
7	Capacitors	$\frac{100 \mu F}{20V}$	1

THEORY:

The basic **RC Oscillator** which is also known as a **Phase-shift Oscillator**, produces a sine wave output signal using regenerative feedback obtained from the resistor-capacitor combination. This regenerative feedback from the RC network is due to the ability of the capacitor to store an electric charge, (similar to the LC tank circuit).

This resistor-capacitor feedback network can be connected as shown above to produce a leading phase shift (phase advance network) or interchanged to produce a lagging phase shift (phase retard network) the outcome is still the same as the sine wave oscillations only occur at the frequency at which the overall phase-shift is 360°.

By varying one or more of the resistors or capacitors in the phase-shift network, the frequency can be varied and generally this is done by keeping the resistors the same and using a 3-ganged variable capacitor.

If all the resistors, R and the capacitors, C in the phase shift network are equal in value, then the frequency of oscillations produced by the RC oscillator is given as:

$$f_r = \frac{1}{2\pi RC\sqrt{2N}}$$

Where:

 f_r is the Output Frequency in Hertz

R is the Resistance in Ohms

C is the Capacitance in Farads

N is the number of RC stages. ($N = 3$)

CIRCUIT DIAGRAM:

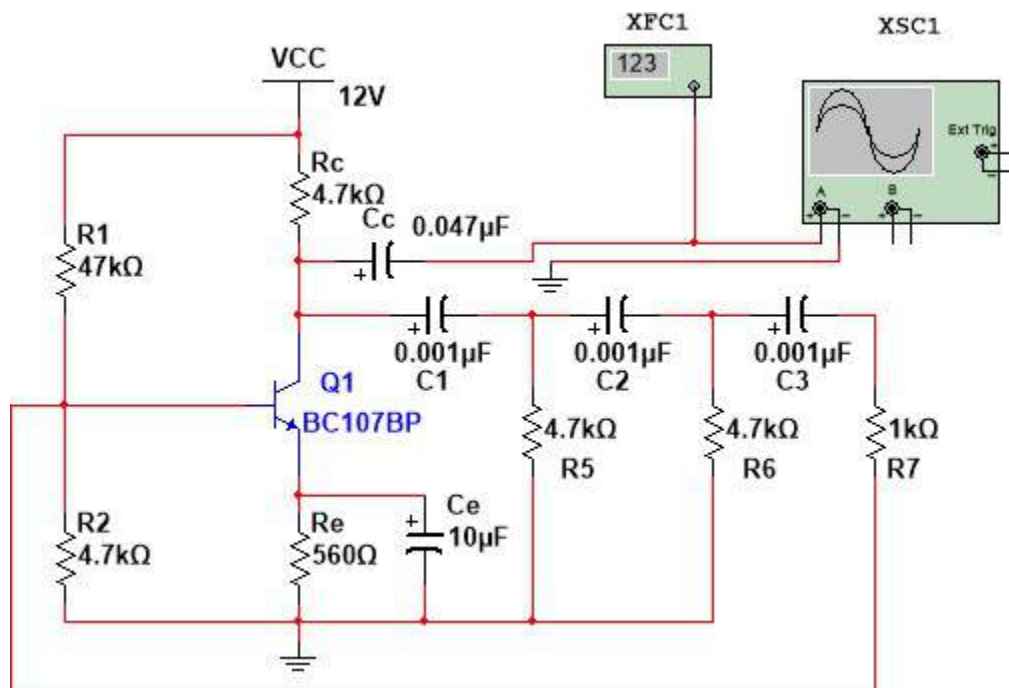

RC PHASESHIFT OSCILLATOR

OBSERVATIONS/GRAPHS:

$C1=C2=C3=0.001\mu$

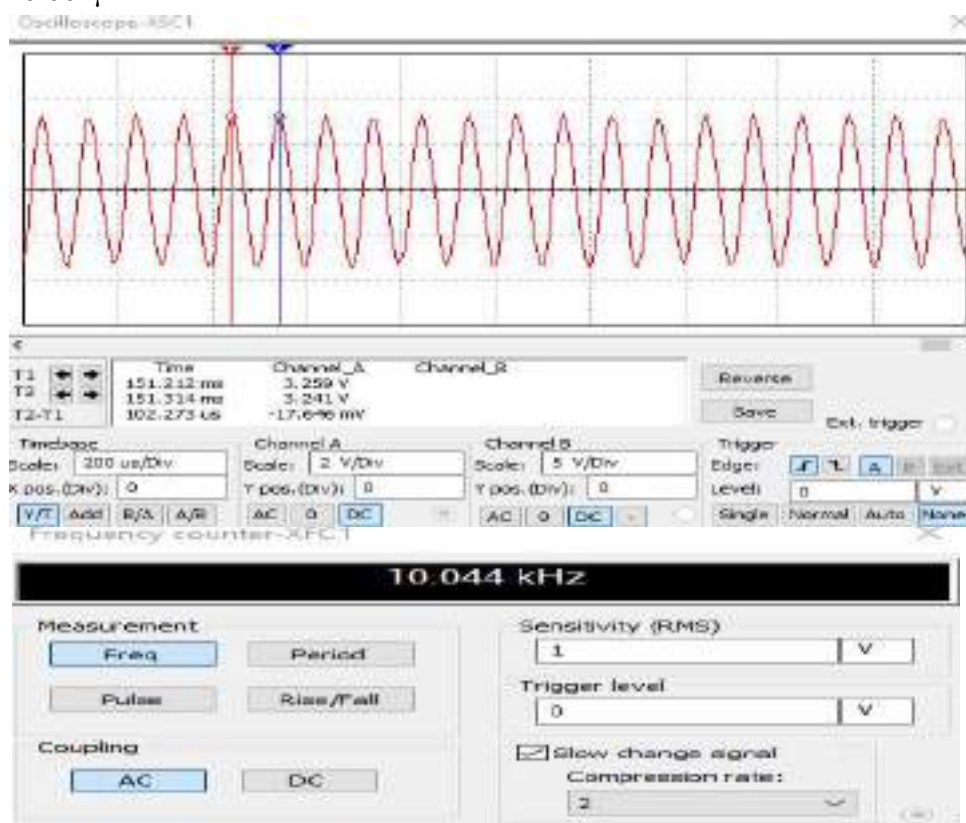

Since the resistor-capacitor combination in the **RC Oscillator** circuit also acts as an attenuator producing an attenuation of $-1/29^{\text{th}}$ ($V_o/V_i = \beta$) per stage, the gain of the amplifier must be sufficient to overcome the circuit losses. Therefore, in our three stage RC network above the amplifier gain must be greater than 29.

The loading effect of the amplifier on the feedback network has an effect on the frequency of oscillations and can cause the oscillator frequency to be up to 25% higher than calculated. Then the feedback network should be driven from a high impedance output source and fed into a low impedance load such as a common emitter transistor amplifier but better still is to use an *Operational Amplifier* as it satisfies these conditions perfectly.

PROCEDURE:

1. Open Multisim Software to design RC Phase shift oscillator
2. Select on New editor window and place the required component on the circuit window.
3. Make the connections using wire and check the connections of oscillator.
4. Go for simulation and using Run Key observe the output waveforms on CRO
5. Observe the Transient Response and Calculate the Frequency of the oscillator

Theoretical calculations:

$$f(\text{practical}) = 1/T \text{ Hz.}$$

$$f_o = \frac{1}{2\pi RC\sqrt{6+4K}} \quad (\text{Theoretical})$$

$$\text{Where } K = R_C / R = 1.$$

$$R_1 = R_2 = R_3 = R.$$

$$C_1 = C_2 = C_3 = C.$$

Results and Discussions:

S.NO.	R	C (μF)			Practical frequency (Hz)	Theoretical Frequency (Hz)
		C ₁	C ₂	C ₃		
1						
2						
3						

$$C1=C2=C3=0.01\mu$$

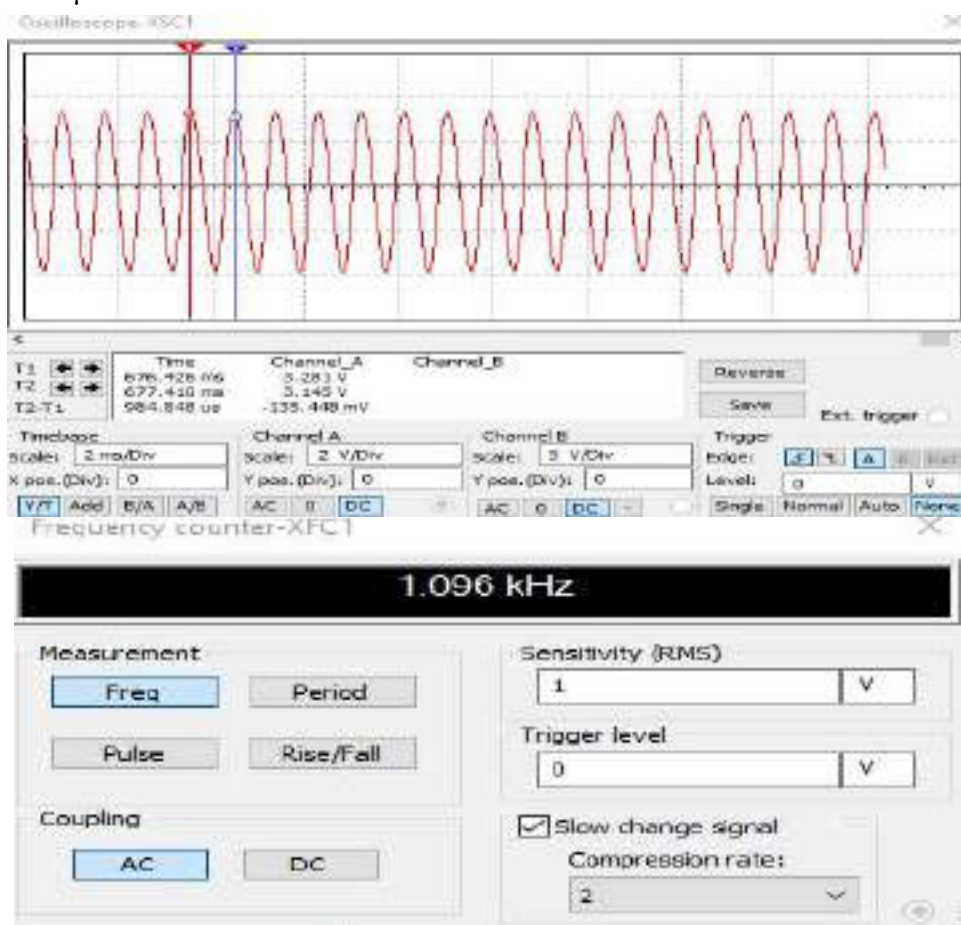

$$C1=C2=C3=0.1\mu, \dots$$

REVIEW QUESTIONS:

1. What are the conditions of oscillations?
2. Give the formula for frequency of oscillations?
3. What is the total phase shift produced by RC ladder network?
4. What are the types of oscillators?
5. What is the gain of RC phase shift oscillator?

EXERCISE:

1. Design RC Phase shift oscillator using FET and different design values
2. Design a PCB layout for RC Phase shift oscillator.

6a. COLPITTS OSCILLATOR

Exp. No:

Date:

AIM: To determine the frequency of oscillations of a given Colpitts Oscillator.

APPARATUS:

S. No	Name	Range / Value	Quantity
1	DC Regulated Power Supply	(0-30V)	1
2	Resistors	560Ω-1, 47 KΩ-1	1
4	Resistors	4.7 KΩ-2	1
5	Capacitors	100μF-1, 0.047μF-1	Each 1
6	Decade Inductance Box	--	1
7	Decade Capacitance Box	--	2
8	CRO	--	1

CIRCUIT DIAGRAM:

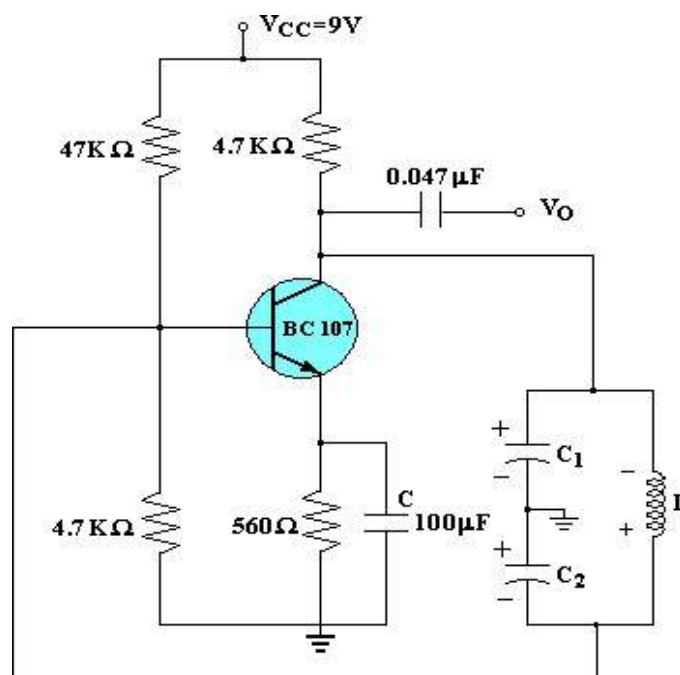

Colpitts Oscillator

OUTPUT WAVEFORM:

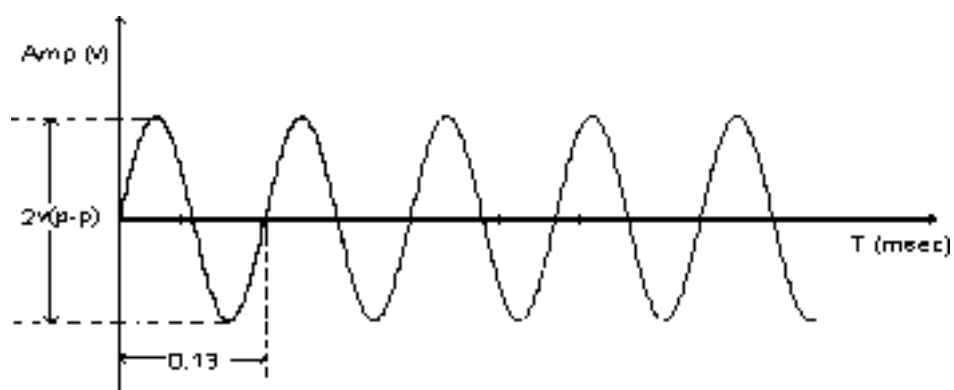

TABULAR FORM:

S.NO.	L (mH)	C (μ F)		Practical frequency (Hz)	Theoretical Frequency (Hz)
		C ₁	C ₂		
1					
2					
3					

THEORY:

In the Colpitts oscillator shown in figure, Z₁, and Z₂ are capacitors and Z₃ is an inductor. The resistors R and R₂ and R_E provide the necessary DC bias to the transistor. C_E is a bypass capacitor C_{C1} and C_{C2} are coupling capacitors. The feedback network consisting of capacitors C₁ and C₂, inductor L determine the frequency of the oscillator.

When the supply voltage +V_{CC} is switched ON, a transient current is produced in the tank circuit, and consequently damped harmonic oscillations are setup in the circuit. The current in tank circuit produces AC voltages across C₁ and C₂. As terminal 3 is earthed, it will be at zero potential.

If terminal 1 is at positive potential with respect to 3 at any instant, then terminal 2 will be at negative potential with respect to 3 at the same instant. Thus the phase difference between the terminals 1 and 2 is always 180°. In the CE mode, the transistor provides the phase difference of 180° between the input and output. Therefore the total phase shift is 360°. The frequency of oscillations is

$$f = \frac{1}{2\pi\sqrt{LC_{eq}}}, \text{ where } \frac{1}{C_{eq}} = \frac{1}{C_1} + \frac{1}{C_2}$$

PROCEDURE:

1. Connect the circuit diagram as shown in the figure.
2. Switch on the power supply.
3. Connect the out put terminals to CRO.
4. Adjust the capacitances until a sinusoidal wave form is observed on the CRO.
5. Measure the time period of the sinusoidal wave form (T) and determine the Frequency (1/T).
6. Repeat the above steps for different values of L, C₁ & C₂.
7. Tabulate the readings and compare with theoretical values

CALCULATIONS:

$$f_0 \text{ (practical)} = 1/T \text{ Hz.}$$

$$f_0 \text{ (theoretical)} = \frac{1}{2\pi\sqrt{LC_{eq}}} \cdot \left[\text{Where } C_{eq} = \frac{C_1 C_2}{C_1 + C_2} \right]$$

RESULT:

VIVA QUESTIONS:

1. Why RC network oscillator cannot be used at Radio frequencies?
2. Why LC network oscillators are preferred at high frequencies?
3. Why a buffer amplifier is required in between an oscillator and a load?
4. What is meant by ringing in an amplifier?
5. Why the crystal oscillator is highly stable?
6. Draw the electrical equivalent circuit of a crystal oscillator?

Extra:

1. Define oscillator.
2. Which type of Feedback is employed in oscillator?
3. What are the applications of Colpitts oscillator?
4. What is meant by resonant Circuit Oscillators?
5. Define gain and phase Margin?
6. What is a beat frequency oscillator?
7. What is damped Oscillation?
8. Write the expression for frequency of oscillations for colpitts and hartley oscillators?
9. Classify the different types of Oscillators?
10. What are the factors that determine the stability of an oscillator?

6b. COLPITTS OSCILLATOR (Using Simulation)

Exp. No:

Date:

PRELAB:

Study the operation and working principle Hartley oscillator.

OBJECTIVE:

To design Colpitts oscillator using Multisim software and calculate the frequency for different LC Values

SOFTWARE TOOL:

- Multisim

APPARATUS:

S. No	Name	Range / Value	Quantity
1	DC Regulated Power Supply	(0-30V)	1
2	Resistors	560Ω, 47 KΩ	1
4	Resistors	4.7 KΩ	2
5	Capacitors	100μF, 0.047μF	Each 1
6	Inductor(Variable Type)	--	1
7	Capacitors	--	2
8	CRO	--	1

THEORY:

A Colpitts oscillator is the electrical dual of a Hartley oscillator, where the feedback signal is taken from inductive voltage divider consisting of two coils in series (Tapped inductor) below figure shows the Colpitts circuit. L and the series combination of C_1 and C_2 form the parallel resonant tank circuit which determines the frequency of the oscillator. The voltage across C_2 is applied to the base-emitter junction of the transistor, as feedback to create oscillations. Here the voltage across C_1 provides feedback. The frequency of oscillation is approximately the resonant frequency of the LC circuit, which is the series combination of the two capacitors in parallel with the inductor

$$f_0 = \frac{1}{2\pi\sqrt{L\left(\frac{C_1C_2}{C_1+C_2}\right)}}$$

CIRCUIT DIAGRAM:

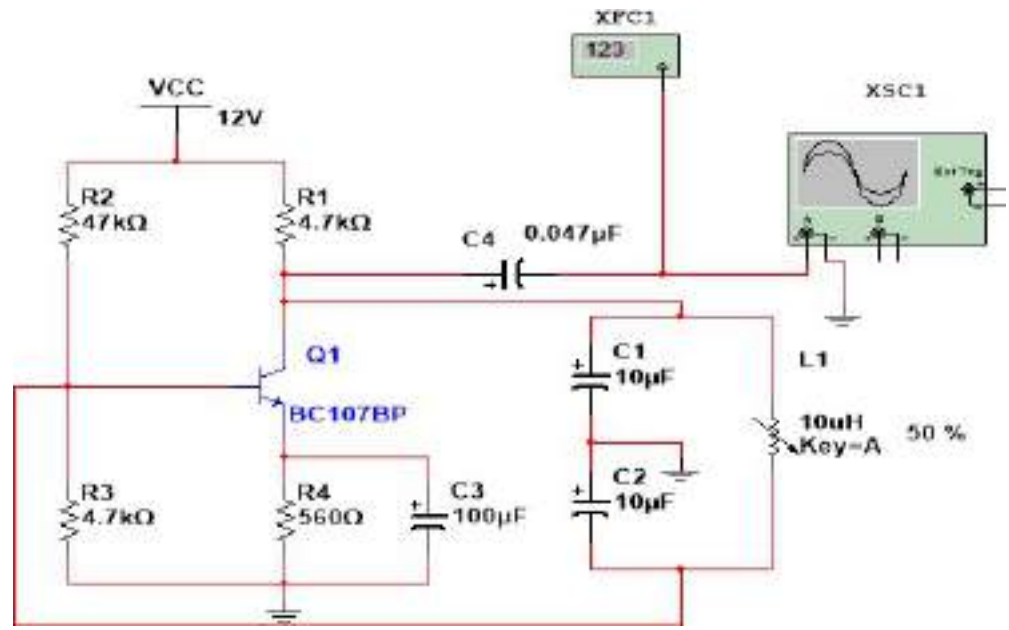

Colpitts Oscillator

Output waveform:

C1=C2=10u, L = 1u



PROCEDURE:

1. Connect the circuit diagram as shown in the figure.
2. Switch on the power supply.
3. Connect the output terminals to CRO.
4. Adjust the capacitances until a sinusoidal wave form is observed on the CRO.
5. Measure the time period of the sinusoidal wave form (T) and determine the Frequency (1/T).
6. Repeat the above steps for different values of L, C₁ & C₂.
7. Tabulate the readings and compare with theoretical values

RESULTS & DISCUSSIONS:

C₁=C₂= 10 μ ; L= 3 μ

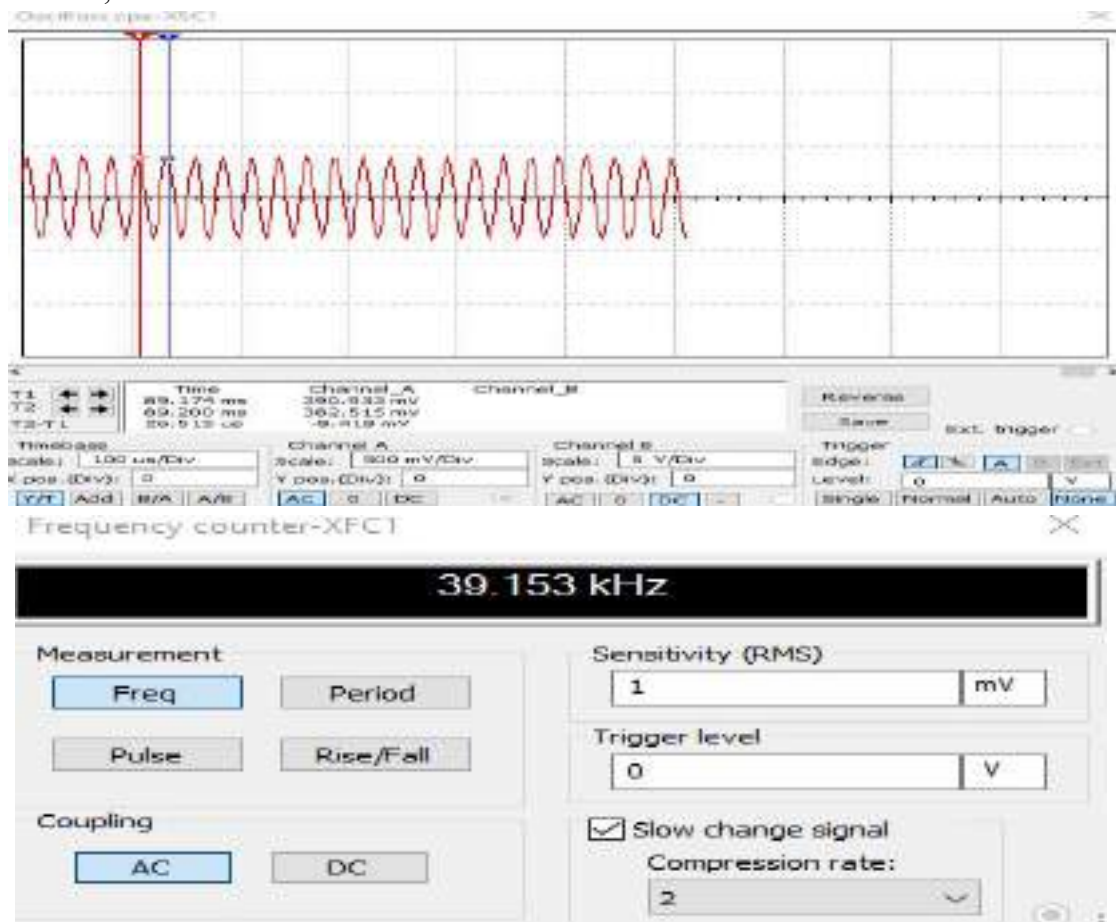

C1=C2=10u; L = 5u

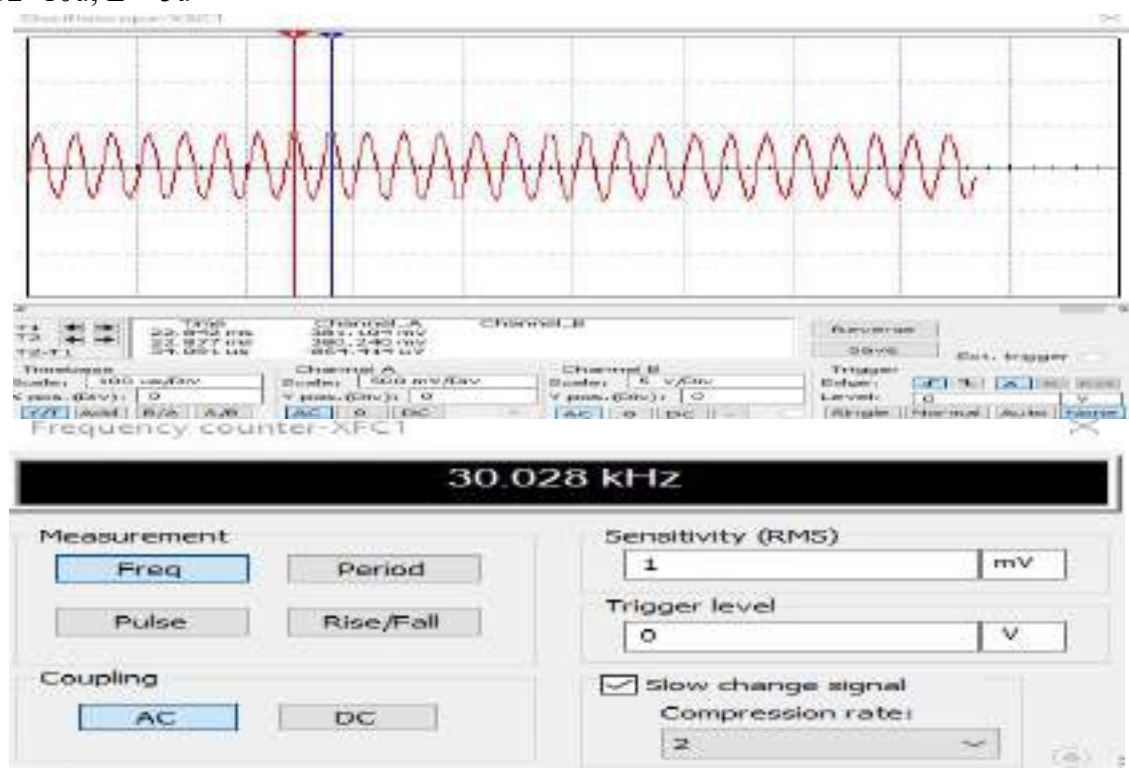

VIVA QUESTIONS:

1. Why RC network oscillator cannot be used at Radio frequencies?
2. Why LC network oscillators are preferred at high frequencies?
3. Why a buffer amplifier is required in between an oscillator and a load?
4. What is meant by ringing in an amplifier?
5. Why the crystal oscillator is highly stable?
6. Draw the electrical equivalent circuit of a crystal oscillator?

Formulae:

f_0 (practical) = $1/T$ Hz.
 f_0 (theoretical) = $\frac{1}{2\pi\sqrt{LC_{eq}}}$. [Where $C_{eq} = \frac{C_1 C_2}{C_1 + C_2}$]

TABULAR FORM:

S.NO.	L (mH)	C (μF)		Practical frequency (Hz)	Theoretical Frequency (Hz)
		C ₁	C ₂		
1					
2					
3					

Theoretical calculations:

7a. HARTLEY OSCILLATOR

Exp. No:

Date:

AIM: To Determine the frequency of oscillations of a Hartley Oscillator and compare it with the theoretical values.

APPARATUS:

S. No	Name	Range / Value	Quantity
1	D.C Regulated Power Supply	(0 – 30V)	1
2	Resistors	1K Ω , 10k Ω , 47K Ω	Each 1
3	Capacitors	0.22 μ F -2	1
4	Decade Capacitance Box	--	1
5	Decade Inductance Box	--	2
6	CRO	--	1

CIRCUIT DIAGRAM:

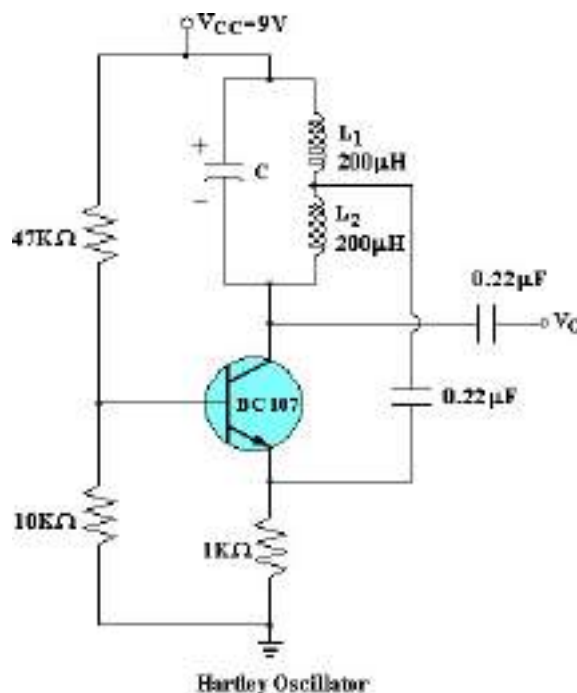

THEORY:

In the Colpitts oscillator shown in figure, Z1, and Z2 are inductor and Z3 is an capacitors. The resistors R and R2 and RE provide the necessary DC bias to the transistor. CE is a bypass capacitor CC1 and CC2 are coupling capacitors. The feedback network consisting of capacitors C, inductor L₁ and L₂ determine the frequency of the oscillator.

When the supply voltage +VCC is switched ON, a transient current is produced in the tank circuit, and consequently damped harmonic oscillations are setup in the circuit. The current in tank circuit produces AC voltages across L₁ and L₂. As terminal 3 is earthed, it will be at zero potential.

If terminal is at positive potential with respect to 3 at any instant, then terminal 2 will be at negative potential with respect to 3 at the same instant. Thus the phase difference between the terminals 1 and 2 is always 180° . In the CE mode, the transistor provides the phase difference of 180° between the input and output. Therefore the total phase shift is 360° . The frequency of oscillations is $f_0 = \frac{1}{2\pi\sqrt{L_{eq}C}}$

PROCEDURE:

1. Connect the circuit as shown in the figure.
2. Connect the O / P of the oscillator to the C.R.O.
3. Adjust the Capacitance and Inductance Boxes until a sinusoidal signal is observed In the CRO.
4. Determine the frequency of the wave form.
5. Vary the Capacitance in convenient steps and determine the frequency each time
6. Tabulate the readings and compare the readings with the theoretical values.

FORMULAS:

Theoretical Frequency $f_0 = \frac{1}{2\pi\sqrt{L_{eq}C}}$

Practical Frequency F: $\frac{1}{T}$

CALCULATIONS:

TABULAR FORM:

Capacitance C (μ F)	Inductance (m H)		Practical Frequency (Hz)	Theoretical Frequency (Hz)
	L ₁	L ₂		

RESULT:

VIVA QUESTIONS:

1. Why RC network oscillator cannot be used at Radio frequencies?
2. Why LC network oscillators are preferred at high frequencies?
3. Why a buffer amplifier is required in between an oscillator and a load?
4. What is meant by ringing in an amplifier?
5. Why the crystal oscillator is highly stable?
6. Draw the electrical equivalent circuit of a crystal oscillator?

7b. HARTLEY OSCILLATOR (Using Simulation)

Exp. No:

Date:

PRELAB:

Study the operation and working principle Hartley oscillator.

OBJECTIVE:

To design Hartley oscillator using Multisim software and calculate the frequency

SOFTWARE TOOL:

- Multisim 13.0

APPARATUS:

S. No	Name	Range / Value	Quantity
1	D.C Regulated Power Supply	(0 – 30V)	1
2	Resistors	1K Ω , 10k Ω , 47K Ω	1
3	Capacitors	0.22 μ F	1
4	Decade Capacitance Box	--	1
5	Decade Inductance Box	--	2
6	CRO	--	1

THEORY:

The **Hartley oscillator** is an electronic oscillator circuit in which the oscillation frequency is determined by a tuned circuit consisting of capacitors and inductors, that is, an LC oscillator. The Hartley oscillator is distinguished by a tank circuit consisting of two series-connected coils (or, often, a tapped coil) in parallel with a capacitor, with an amplifier between the relatively high impedance across the entire LC tank and the relatively low voltage/high current point between the coils. The Hartley oscillator is the dual of the Colpitts oscillator which uses a voltage divider made of two capacitors rather than two inductors. Although there is no requirement for there to be mutual coupling between the two coil segments, the circuit is usually implemented using a tapped coil, with the feedback taken from the tap, as shown here. The optimal tapping point (or ratio of coil inductances) depends on the amplifying device used, which may be a bipolar junction transistor.

CIRCUIT DIAGRAM:

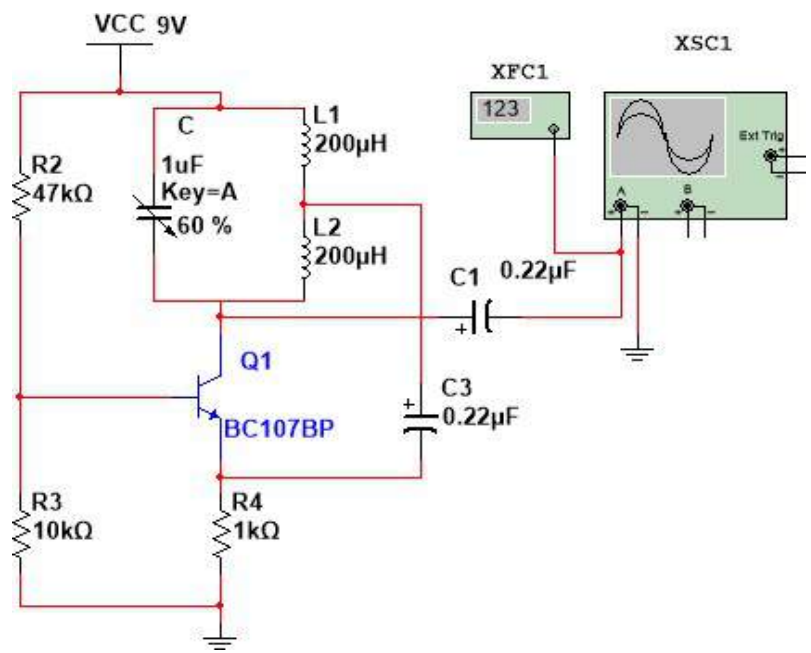

Hartley Oscillator

OUTPUT WAVEFORM:

L1 = L2= 200u; C = 20nf

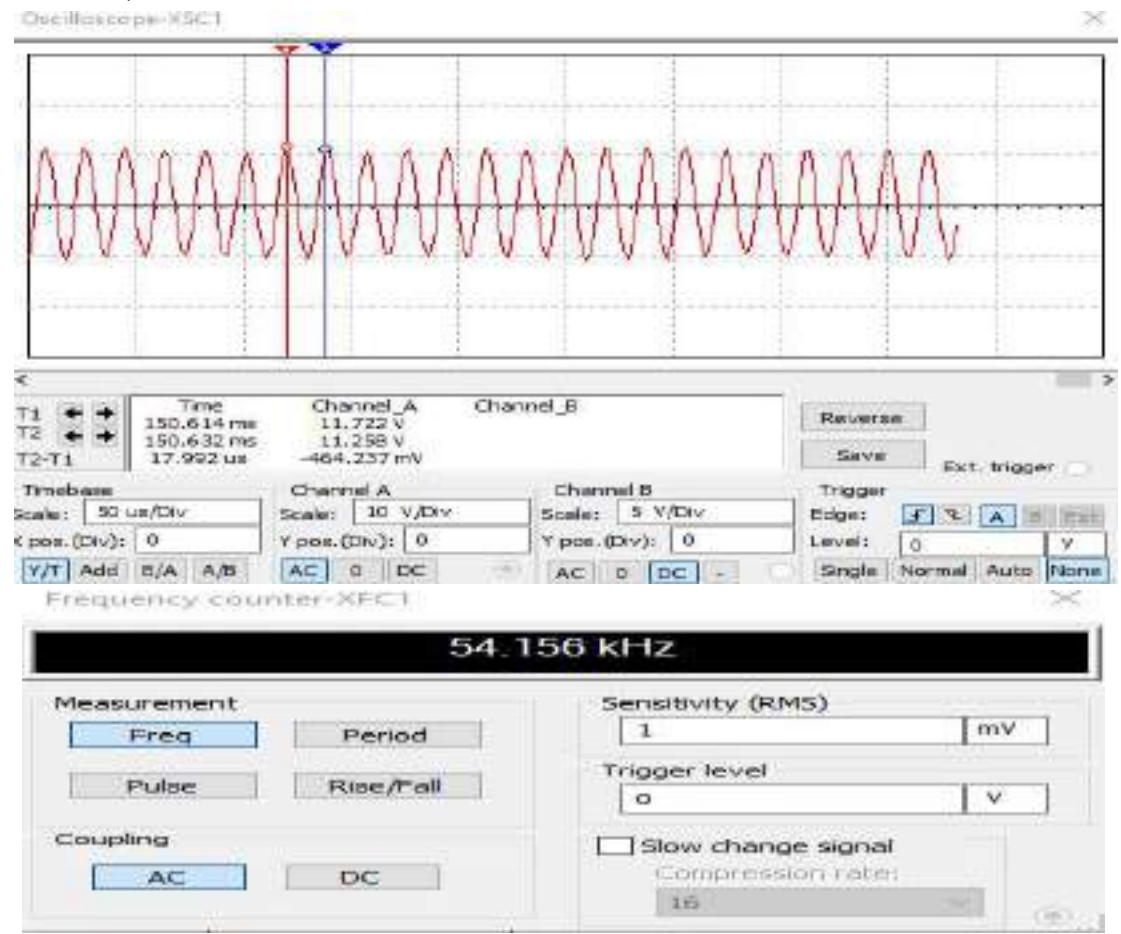

PROCEDURE:

1. Connect the circuit as shown in the figure.
2. Connect the O / P of the oscillator to the C.R.O.
3. Adjust the Capacitance and Inductance Boxes until a sinusoidal signal is observed in the CRO.
4. Determine the frequency of the wave form.
5. Vary the Capacitance in convenient steps and determine the frequency each time
6. Tabulate the readings and compare the readings with the theoretical values.

FORMULAS:

Theoretical Frequency $f_0 = \frac{1}{2\pi\sqrt{L_{eq}C}}$

Practical Frequency $f: \frac{1}{T}$

RESULT & DISCUSSIONS:

L1=L2= 200u; C = 40nf

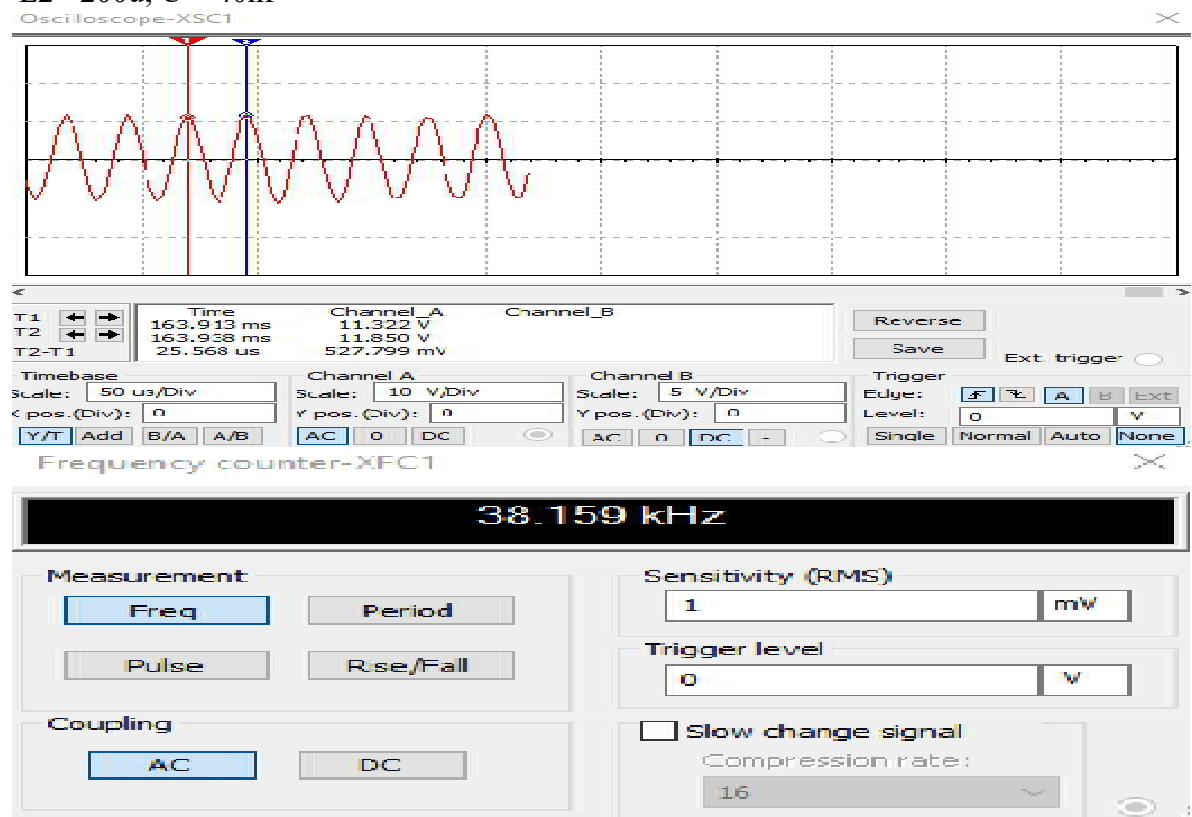

$L_1=L_2= 200\mu$; $C = 80\text{nf}$

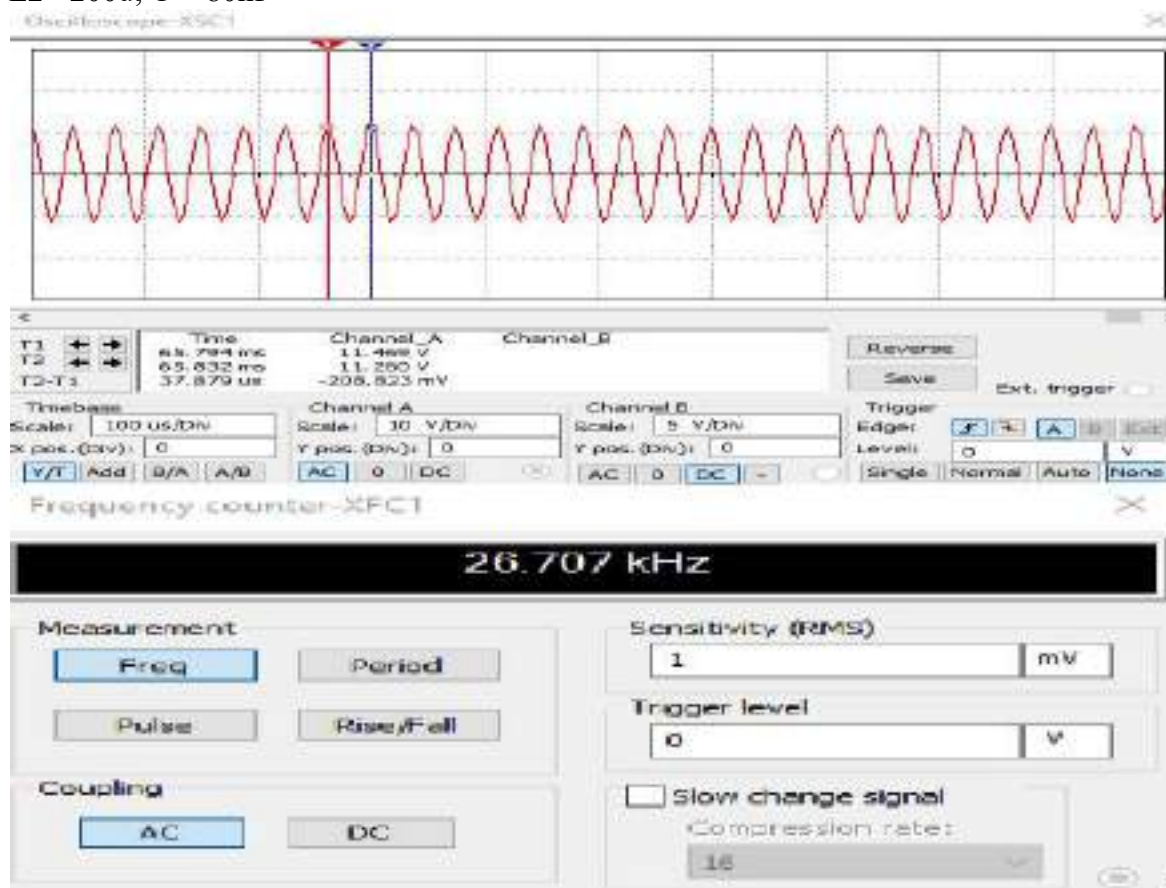

Tabular form:

Capacitance $C (\mu F)$	Inductance (mH)		Practical Frequency (Hz)	Theoretical Frequency (Hz)
	L_1	L_2		

Theoretical calculations:

REVIEW QUESTIONS:

1. Define an oscillator?
2. Define Barkhausen criteria
3. Which type of feedback is employed in oscillators

8a. TWO STAGE RC-COUPLED AMPLIFIER

Exp. No:

Date:

AIM: To pSet the frequency response of Two stage RC – Coupled Amplifier and to obtain its band width.

APPARATUS:

S. No	Name	Range / Value	Quantity
1	D.C Regulated power supply	(0 – 30V)	1
2	Transistors	BC 107	2
3	Resistors	10K Ω , 150K Ω , 47K Ω , 22K Ω , 33K Ω , 2.2K Ω ,1K Ω , 560 Ω , 220 Ω	1
4	Resistors	4.7K Ω	3
5	Capacitors	10 μ F	5
6	Function Generator	--	1
7	CRO	--	1

CIRCUIT DIAGRAM:

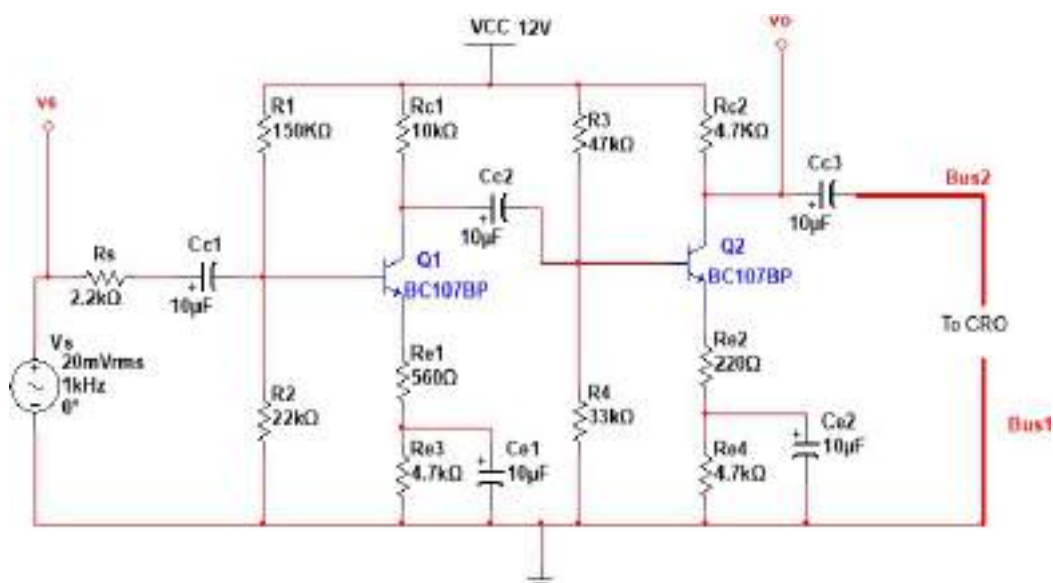

MODEL GRAPH:

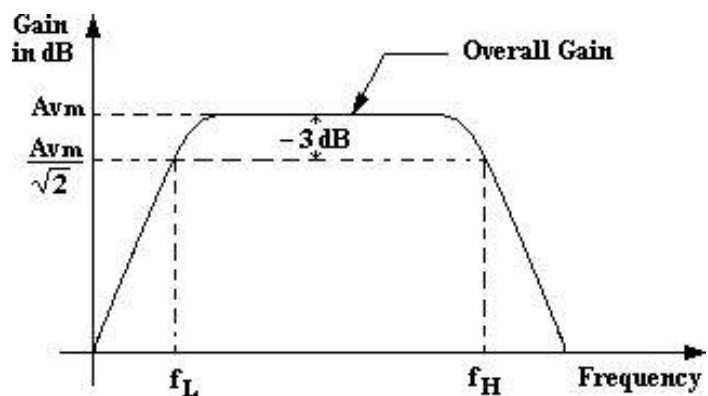

THEORY

As the gain provided by a single stage amplifier is usually not sufficient to drive the load, so to achieve extra gain multi-stage amplifier are used. In multi-stage amplifiers output of one-stage is coupled to the input of the next stage. The coupling of one stage to another is done with the help of some coupling devices. If it is coupled by RC then the amplifier is called RC-coupled amplifier.

Frequency response of an amplifier is defined as the variation of gain with respective frequency. The gain of the amplifier increases as the frequency increases from zero till it becomes maximum at lower cut-off frequency and remains constant till higher cut-off frequency and then it falls again as the frequency increases.

At low frequencies the reactance of coupling capacitor C_C is quite high and hence very small part of signal will pass through from one stage to the next stage. At high frequencies the reactance of inter electrode capacitance is very small and behaves as a short circuit. This increases the loading effect on next stage and service to reduce the voltage gain due to these reasons the voltage gain drops at high frequencies.

At mid frequencies the effect of coupling capacitors is negligible and acts like short circuit, where as inter electrode capacitors acts like open circuit. So, the circuit becomes resistive at mid frequencies and the voltage gain remains constant during this range.

PROCEDURE:

1. Connect the circuit as shown in the figure.
2. Switch on the power supply and the Function generator.
3. Apply a 5mV sinusoidal signal at the I/P.
4. Vary the frequency in convenient steps and note down the O/P voltage.
5. Tabulate the readings and calculate the gain in dB.
6. PSet a graph between gain and frequency.
7. Determine the band width.

TABULAR FORM:

$V_i = 20\text{mV}$				
S.No	Frequency (Hz)	V_o (mV)	Voltage Gain $A_v = (V_o/V_i)$	Gain in dB ($20\log A_v$)
1	50			
2	100			
3	300			
4	500			
5	700			
6	1K			
7	3K			
8	5K			
9	7K			
10	10K			
11	30K			
12	50K			
13	70K			
14	100K			
15	300K			
16	500K			
17	700K			
18	1MHz			

RESULT:

Upper cut-off frequency	=	KHz.
Lower cut-off frequency	=	KHz.
Bandwidth	=	KHz.

VIVA QUESTIONS:

1. What is the need for Two stage Amplifier?
2. Differentiate between interacting and non- interacting stages?
3. Give the expression for the overall upper cut-off frequency of a multistage amplifier?
4. What is the effect of multistage amplifier on band width?
5. What is the choice of transistor configuration in multistage amplifier?
6. What is cascade amplifier?
7. What is the advantage of cascade amplifier?

Extra:

1. What are the advantages and disadvantages of multi-stage amplifiers?
2. Why gain falls at HF and LF?
3. Why the gain remains constant at MF?
4. Explain the function of emitter bypass capacitor, CE?
5. How the band width will effect as more number of stages are cascaded?
6. Define frequency response?
7. Give the formula for effective lower cut-off frequency, when N-number of stages is cascaded?
8. Explain the effect of coupling capacitors and inter-electrode capacitances on overall gain?
9. By how many times effective upper cut-off frequency will be reduced, if three identical stages are cascaded?
10. Mention the applications of two-stage RC-coupled amplifiers?

8b. TWO STAGE RC-COUPLED AMPLIFIER (Using Simulation)

Exp. No:

Date:

PRELAB:

1. Study the purpose of multistage amplifiers.
2. Learn the different types of coupling methods.
3. Study the effect of cascading on Bandwidth.
4. Identify all the formulae you will need in this Lab.
5. Study the procedure of using Multisim tool (Schematic & Circuit File)

OBJECTIVE:

1. To simulate the Two Stage RC Coupled Amplifier in Multisim and study the transient and frequency response.
2. To determine the phase relationship between the input and output voltages by performing the transient analysis.
3. To determine the maximum gain, 3dB gain, lower and upper cutoff frequencies and bandwidth of Two Stage RC Coupled Amplifier by performing the AC analysis.
4. To determine the effect of cascading on gain and bandwidth.

SOFTWARE TOOL:

- Multisim

APPARATUS:

S. No	Name	Range / Value	Quantity
1	D.C Regulated power supply	(0 – 30V)	1
2	Transistors	BC 107	2
3	Resistors	10K Ω , 150K Ω , 47K Ω , 22K Ω , 33K Ω , 2.2K Ω	1
4	Resistors	1K Ω , 560 Ω , 220 Ω	1
5	Capacitors	10 μ F	5
6	Function Generator	--	1
7	CRO	--	1

THEORY:

An amplifier is the basic building block of most electronic systems. Just as one brick does not make a house, a single-stage amplifier is not sufficient to build a practical electronic system. The gain of the single stage is not sufficient for practical applications. The voltage level of a signal can be raised to the desired level if we use more than one stage. When a number of amplifier stages are used in succession (one after the other) it is called a multistage amplifier or a cascade amplifier. Much higher gains can be obtained from the multi-stage amplifiers.

CIRCUIT DIAGRAM:

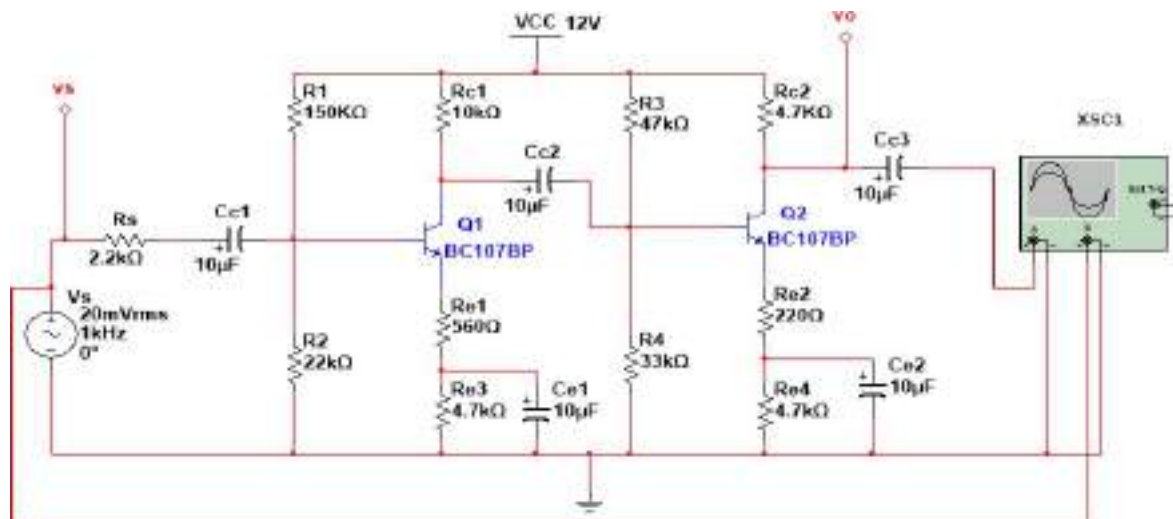

TWO STAGE RC COUPLED AMPLIFIER

OBSERVATIONS/GRAPHS:

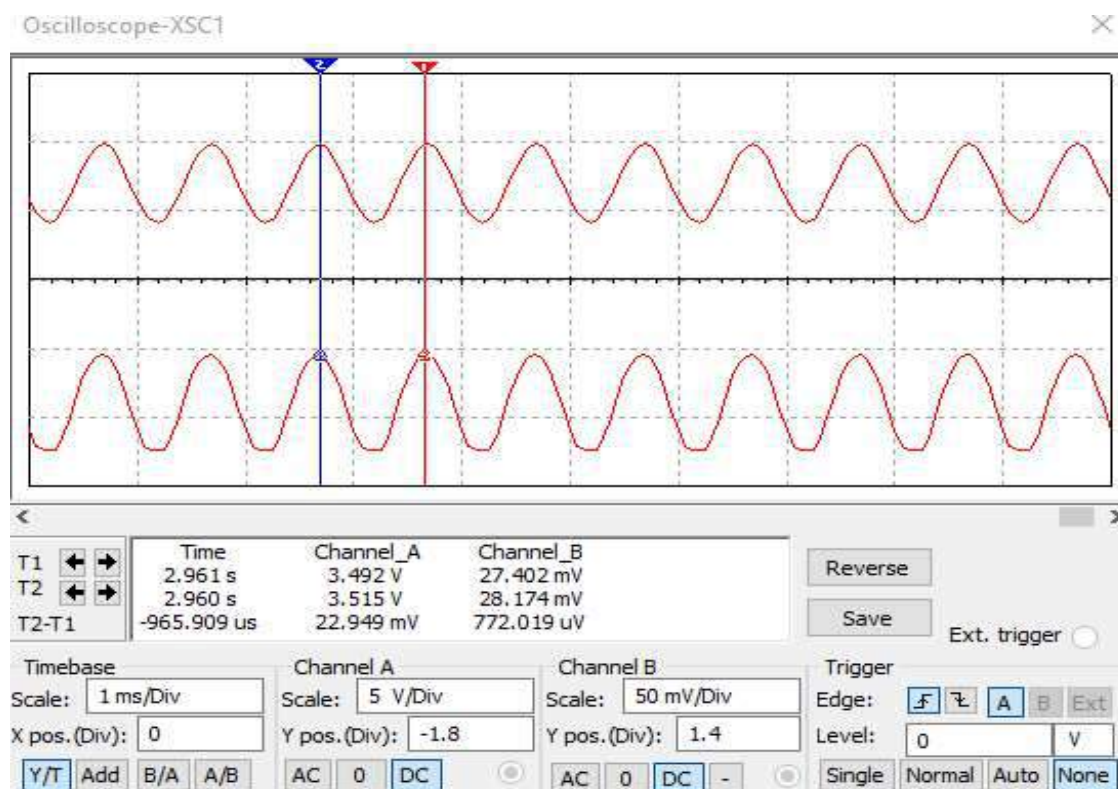

In a multi-stage amplifier, the output of one stage makes the input of the next stage. We must use a suitable coupling network between two stages so that a minimum loss of voltage occurs when the signal passes through this network to the next stage. Also, the dc voltage at the output of one stage should not be permitted to go to the input of the next. If it does, the biasing conditions of the next stage are disturbed. Figure shows how to couple two stages of amplifiers using RC coupling scheme.

This is the most widely used method. In this scheme, the signal developed across the collector resistor R_C (R_2) of the first stage is coupled to the base of the second stage through the capacitor C_C (C_2). The coupling capacitor blocks the dc voltage of the first stage from reaching the base of the second stage. In this way, the dc biasing of the next stage is not interfered with. For this reason, the capacitor C_C (C_2) is also called a blocking capacitor. As the number of stages increases, the gain increases and the bandwidth decreases.

RC coupling scheme finds applications in almost all audio small-signal amplifiers used in record players, tape recorders, public-address systems, radio receivers, television receivers, etc.

PROCEDURE:

1. Open Multisim Software to design two stage RC coupled amplifier circuit
2. Select on New editor window and place the required components of amplifier on the circuit window.
3. Make the connections using wire and check the connections of oscillator.
4. Go for simulation and using Run Key observe the output waveforms on CRO
5. Indicate the node names and go for AC Analysis with the output node
6. Observe the Transient response and Ac Analysis for the first stage and second stage separately and draw the magnitude response curve
7. Calculate the bandwidth of the amplifier

INFERENCE:

1. From the transient analysis, it is observed that, _____
2. From the frequency response curve the results observed are tabulated in table 1.
3. From the AC response, it is observed that, _____

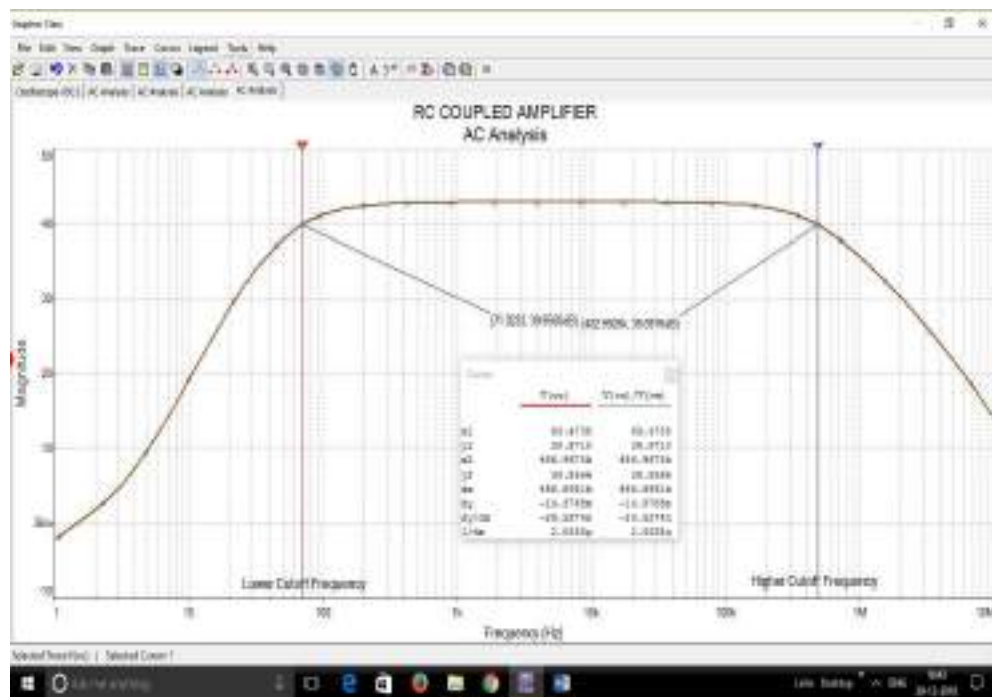

Observation points:

S. No.	Parameter	Value
1	Max. Gain in dB	
2	3dB Gain	
3	Lower Cutoff Frequency	
4	Upper Cutoff Frequency	
5	Bandwidth of 1 stage	
6	Bandwidth of 2 stage	

REVIEW QUESTIONS:

1. Why do you need more than one stage of amplifiers in practical circuits?
2. What is the effect of cascading on gain and bandwidth?
3. What happens to the 3dB frequencies if the number of stages of amplifiers increases?
4. Why we use a logarithmic scale to denote voltage or power gains, instead of using the simpler linear scale?
5. What is loading effect in multistage amplifiers?

EXERCISE:

1. Design two stage amplifier using different FET transistors.
2. Design a PCB layout for the two stages RC coupled Amplifier.

9a. TUNED VOLTAGE AMPLIFIER

Exp. No:

Date:

AIM: To obtain the frequency response of a tuned voltage amplifier.
And to obtain the band width.

APPARATUS:

S. No	Name	Range / Value	Quantity
1	Transistor	SL100	1
2	Resistors	1K Ω , 22 K Ω , 1.8K Ω , 470 Ω	Each 1
3	Capacitors	10F, 33F	1
4	IF Transformer	--	1

CIRCUIT DIAGRAM:

MODEL GRAPH:

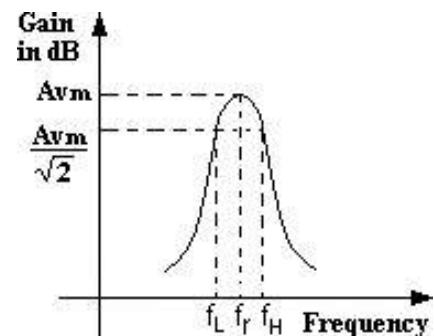
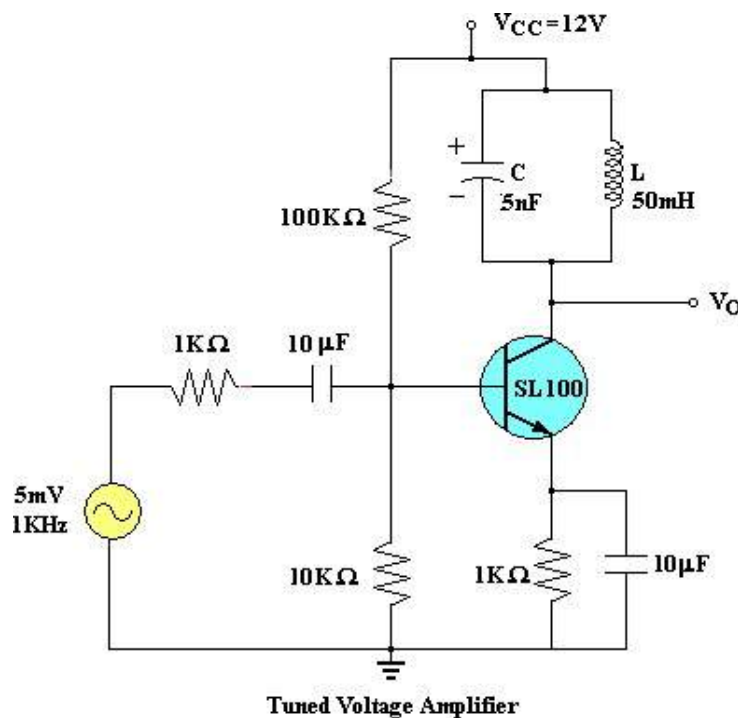

THEORY

The amplifier is said to be class C amplifier, if the Q point and the input signal are selected such that the output signal is obtained for less than a half cycle, for a full input cycle. Due to such a selection of the Q point, transistor remains active, for less than a half cycle. Hence only that much part is reproduced at the output. For remaining cycle of the input cycle, the transistor remains cut-off and no signal is produced at the output. Here a parallel resonant circuit acts as a load impedance. As collector current flows for less than half cycle, the collector current consists of a series of pulses with the harmonics of the input signal.

A parallel tuned circuit acting as a load impedance is tuned the input frequency. Therefore, it filters the harmonic frequencies and produce a sine wave output voltage consisting of fundamental component of the input signal. A class C tuned amplifier can be used as a

frequency multiplier if the resonant circuit is tuned to a harmonic of the input signal. Here class-C amplifier is used with parallel tuned circuit. Therefore the output voltage is a maximum at the resonant frequency. The resonant frequency for parallel tuned circuit is given as

$$\text{Resonant frequency} = F_r = \frac{1}{2\pi\sqrt{LC}}$$

PROCEDURE:

1. Connect the circuit as shown in the figure.
2. Apply a 4 mV sinusoidal signal at a frequency of 1 KHz and note down the O/P.
3. Now vary the frequency of the input signal upto 1MHz in suitable steps by keeping the input voltage constant.
4. Note down the O/P voltage V_0 .
5. Tabulate the readings.
6. Draw gain Vs frequency graph on semilog sheet and determine the band width.

RESULT:

TABULAR FORM:

$$V_i = 5\text{mV}$$

S.No	Frequency (Hz)	Output Voltage (V_0) (mV)	Gain in dB = $20 \log (V_0 / V_i)$
1	50		
2	100		
3	300		
4	500		
5	700		
6	1K		
7	3K		
8	5K		
9	7K		
10	10K		
11	30K		
12	50K		
13	70K		
14	100K		
15	300K		
16	500K		
17	700K		
18	1MHz		

VIVA QUESTIONS:

1. What is a tuned amplifier?
2. Distinguish between a single tuned and a double tuned amplifier?
3. What is meant by stagger tuned amplifier?
4. Is the tuned amplifier a narrow band or a wide band amplifier?
5. Define selectivity?
6. What parameters shall be selected for a highly tuned amplifier?
7. Where the tuned amplifiers are used?
8. What type of tuning is used in the IF stage of a Radio receiver ?
9. What is the relation between the band width of a double tuned and a stagger tuned amplifier?
10. How to improve the band width of a tuned amplifier?
11. What is meant by critical tuning?

9b. TUNED VOLTAGE AMPLIFIER

Exp. No:

Date:

PREAMBLE:

Study the operation and working principle Tuned amplifier.

OBJECTIVE:

To obtain the frequency response of a tuned voltage amplifier using Multisim and to obtain the band width.

SOFTWARE TOOL:

- Multisim

APPARATUS:

S. No	Name	Range / Value	Quantity
1	Transistor	SL100/BC 107	1
2	Resistors	1K Ω ,100K Ω ,10k Ω	2,1,1
3	Capacitors	10uF,5nf,0.047uf	2,1,1
4	Inductor	50mH	1
5	RPS	12V	1
6	CRO	30MHz	1

THEORY:

Most of the audio amplifiers we have discussed in the earlier chapters will also work at radio frequencies i.e. above 50 kHz. However, they suffer from two major drawbacks. First, they become less efficient at radio frequency. Secondly, such amplifiers have mostly resistive loads and consequently their gain is independent of signal frequency over a large bandwidth. In other words, an audio amplifier amplifies a wide band of frequencies equally well and does not permit the selection of a particular desired frequency while rejecting all other frequencies. However, sometimes it is desired that an amplifier should be selective i.e. it should select a desired frequency or narrow band of frequencies for amplification.

For instance, radio and television transmission are carried on a specific radio frequency assigned to the broadcasting station. The radio receiver is required to pick up and amplify the radio frequency desired while discriminating all others. To achieve this, the simple resistive load is replaced by a parallel tuned circuit whose impedance strongly depends upon frequency. Such a tuned circuit becomes very selective and amplifies very strongly signals of resonant frequency and narrow band on either side. Therefore, the use of tuned circuits in conjunction with a transistor makes possible the selection and efficient amplification of a particular desired radio frequency. Such an amplifier is called a tuned amplifier. In this chapter, we shall focus our attention on transistor tuned amplifiers and their increasing applications in high frequency electronic circuits.

CIRCUIT DIAGRAM:

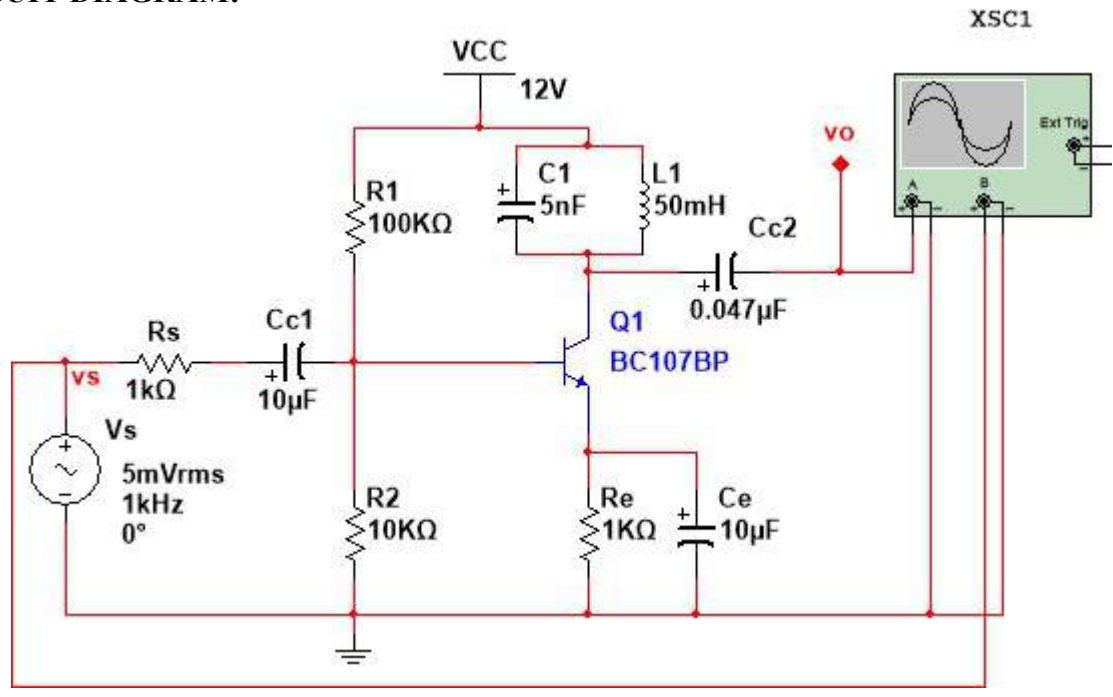

TUNED VOLTAGE AMPLIFIER

OBSERVATIONS/GRAPHS:

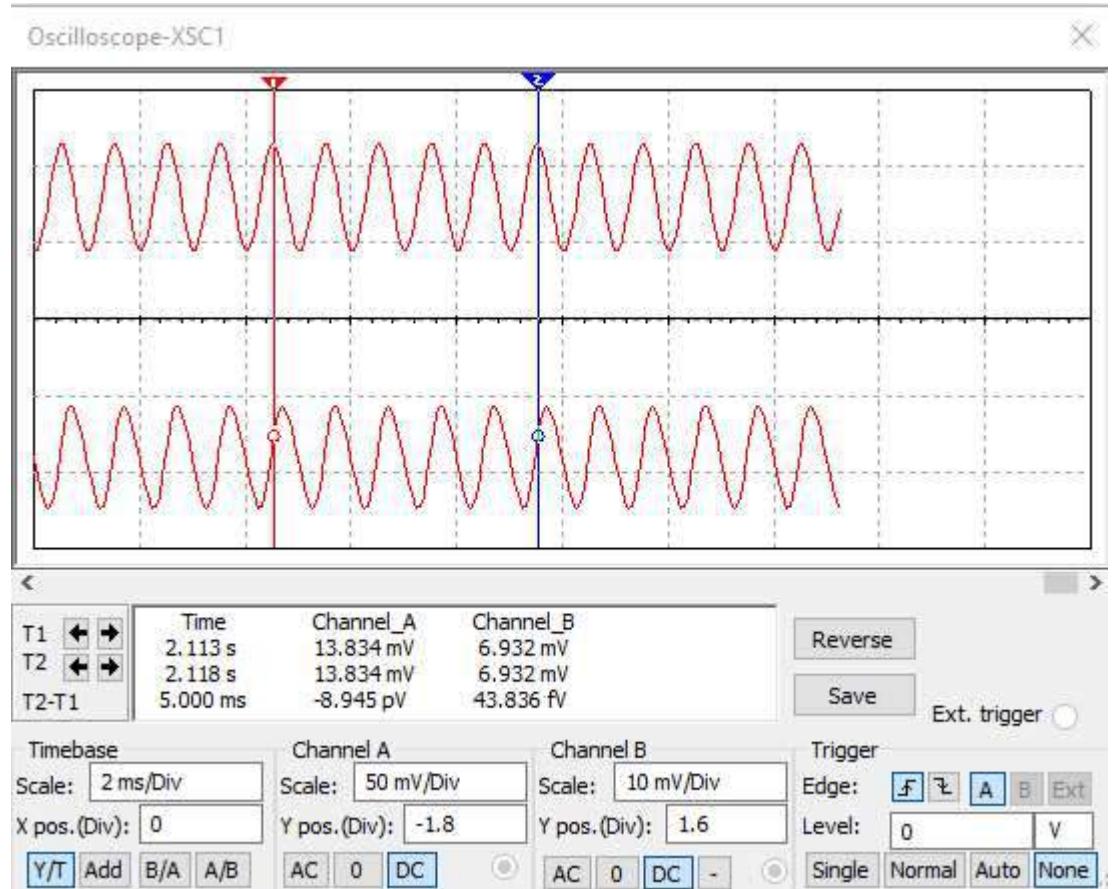

Input and Output waveforms

Amplifiers which amplify a specific frequency or narrow band of frequencies are called tuned amplifiers. Tuned amplifiers are mostly used for the amplification of high or radio frequencies. It is because radio frequencies are generally single and the tuned circuit permits their selection and efficient amplification. However, such amplifiers are not suitable for the amplification of audio frequencies as they are mixture of frequencies from 20 Hz to 20 kHz and not single. Tuned amplifiers are widely used in radio and television circuits where they are called upon to handle radio frequencies. Below figure shows the circuit of a simple transistor tuned amplifier. Here, instead of load resistor, we have a parallel tuned circuit in the collector. The impedance of this tuned circuit strongly depends upon frequency. It offers a very high impedance at resonant frequency and very small impedance at all other frequencies. If the signal has the same frequency as the resonant frequency of LC circuit, large amplification will result due to high impedance of LC circuit at this frequency. When signals of many frequencies are present at the input of tuned amplifier, it will select and strongly amplify the signals of resonant frequency while rejecting all others. Therefore, such amplifiers are very useful in radio receivers to select the signal from one particular broadcasting station when signals of many other frequencies are present at the receiving aerial.

PROCEDURE:

1. Open Multisim Software to design circuit
2. Select on New editor window and place the required component on the circuit window.
3. Make the connections using wire and check the connections and oscillator.
4. Go for simulation and using Run Key observe the output waveforms on CRO
5. Indicate the node names and go for AC Analysis with the output node
6. Observe the Ac Analysis and draw the magnitude response curve
7. Calculate the bandwidth of the amplifier

RESULT & DISCUSSION:

1. Frequency response of single tuned Amplifier is pSetted.
2. Gain = _____ dB (maximum).
3. Bandwidth= $(f_H - f_L) =$ _____ Hz.

Frequency Response:

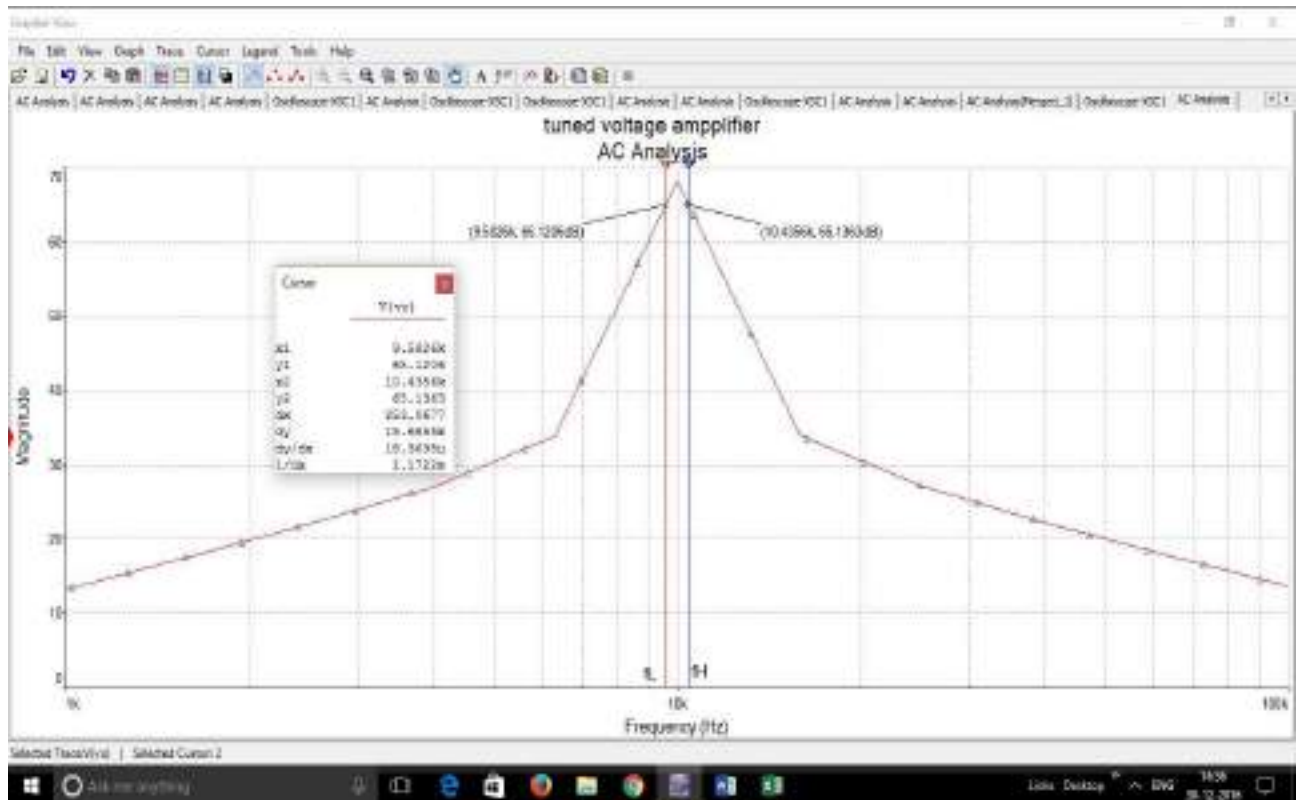

Theoretical calculations:

REVIEW QUESTIONS:

1. What is a tuned amplifier?
2. Define Q-factor?
3. What is selectivity?
4. Is tuned amplifier a narrow band or wide band amplifier?
5. Give the applications for tuned amplifier.

10a. DARLINGTON PAIR AMPLIFIER

Exp. No:

Date:

AIM: Perform the frequency response of a Darlington amplifier. Calculate gain. Calculate bandwidth.

COMPONENTS REQUIRED:

1. Transistor (NPN, Si) BC 547 : 2 Nos.
2. Electrolytic Capacitor 10 μ F : 2Nos.
3. Carbon film Resistors 82 k Ω , 22 k Ω , 2.2 k Ω , 390 Ω , 1 k Ω : 1 No. each

MEASURING INSTRUMENTS:

1. 20 MHz Dual trace CRO : 1 No.
2. 1 MHz Function Generator : 1 No.

MISCELLANEOUS:

1. Trainer Module : 1 No.
2. 0–30 V, 1 A DC Power Supply : 1 No.
3. Connecting wires : 1 Set.

CIRCUIT DIAGRAM:

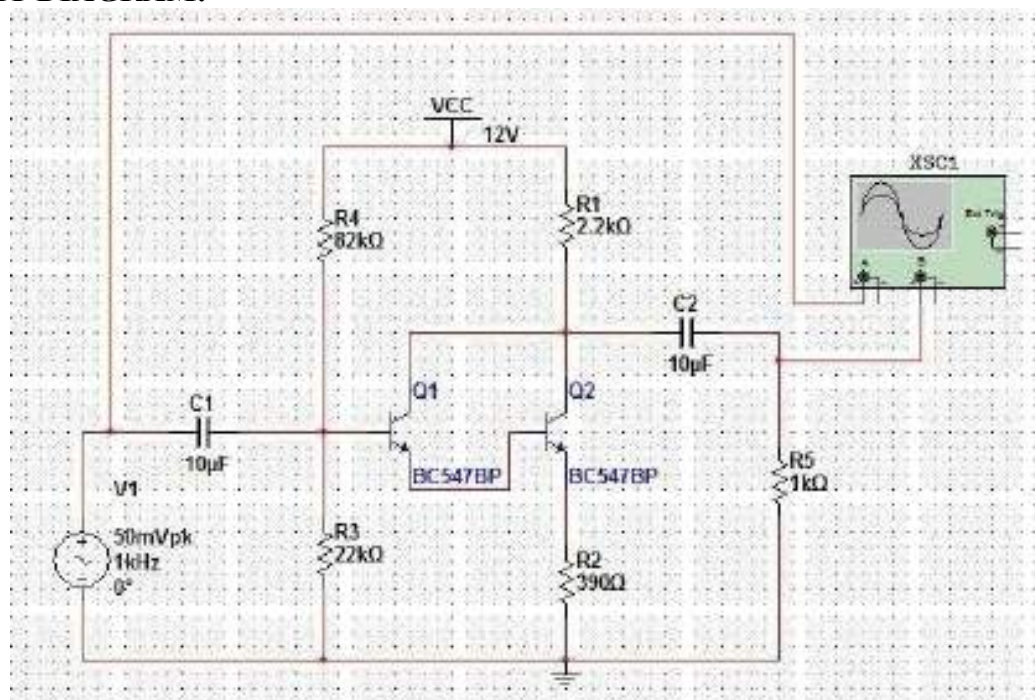

THEORY:

In Darlington connection of transistors, emitter of the first transistor is directly connected to the base of the second transistor. Because of direct coupling dc output current of the first stage is $(1+h_{fe})I_{b1}$. If Darlington connection for n transistor is considered, then due to direct coupling the dc output current for last stage is $(1+h_{fe})^n$ times I_{b1} . Due to very large amplification factor even two stage Darlington connection has large output current and output stage may have to be a power stage. As the power amplifiers are not used in the amplifier circuits it is not possible to use more than two transistors in the Darlington connection.

In Darlington transistor connection, the leakage current of the first transistor and overall leakage current may be high, which is not desired.

Tabular Form:

S. No	Frequency (Hz)	Output Voltage (V ₀)	Voltage Gain (A _v)=V _o /V _i .	V _i =20mV
				Gain in dB A _v =20log(V _o /V _i)
1	50			
2	100			
3	300			
4	500			
5	700			
6	1K			
7	3K			
8	5K			
9	7K			
10	10K			
11	30K			
12	50K			
13	70K			
14	100K			
15	300K			
16	500K			
17	700K			
18	1MHz			

PROCEDURE:

1. Connect the circuit as shown in figure.
2. Apply supply voltage V_{cc}=12 V
3. Keep V_i=20 mV by keeping frequency of function generator at 1kHz.
4. Keep input constant throughout the experiment.
5. Vary the input frequency 50 Hz to 1 MHz and note down the output voltage.
6. Calculate the gain of the amplifier in decibels using the formula gain in
dB=20log(V_o/V_i).
7. PSet the graph between frequencies Vs Gain.

RESULT:

VIVA-VOCE QUESTIONS:

1. Why do you need more than one stage of amplifiers in practical circuits?
2. What is the effect of cascading on gain and bandwidth?
3. What happens to the 3dB frequencies if the number of stages of amplifiers increases?
4. Why we use a logarithmic scale to denote voltage or power gains, instead of using the simpler linear scale?
5. What is loading effect in multistage amplifiers?
6. How a Darlington pair works?
7. The cascode amplifier is a multistage configuration of ?
8. The output impedance of a Darlington pair Amplifier is ?
9. The current gain of a Darlington pair amplifier is approximately?
The CE amplifier configuration is preferred over others. why?

10b. DARLINGTON PAIR AMPLIFIER (Using Simulation)

Exp. No:

Date:

AIM: Perform the frequency response of a Darlington amplifier. Calculate gain. Calculate bandwidth using Simulation.

CIRCUIT DIAGRAM:

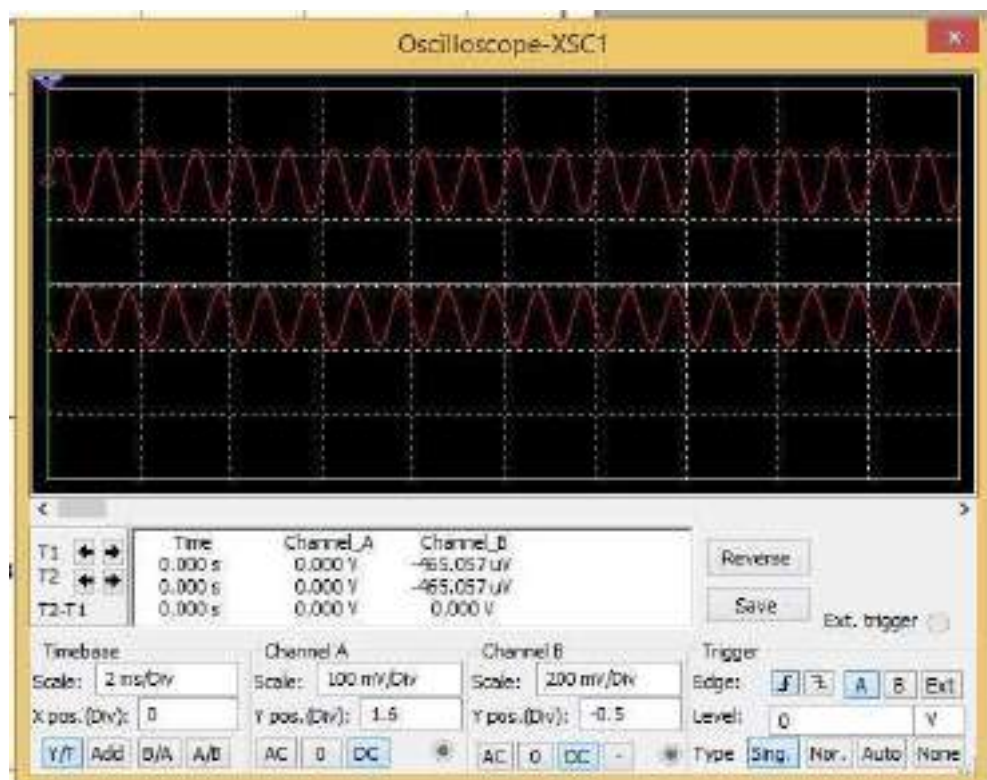
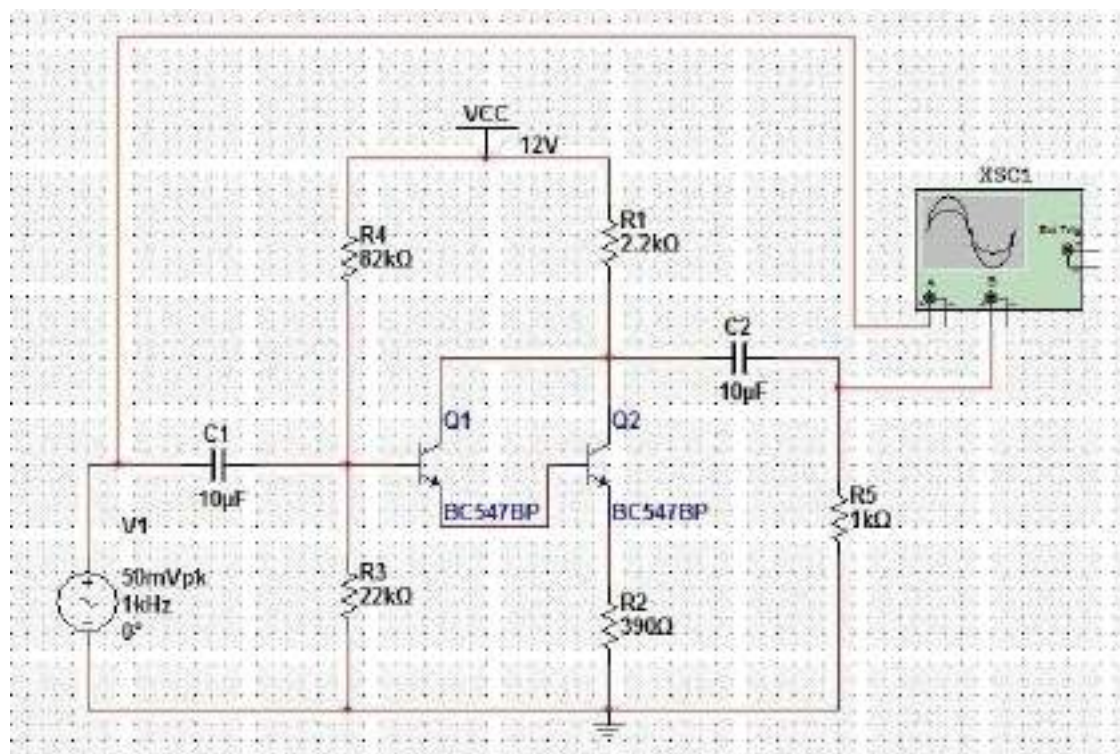

Tabular Form:

$V_i=20\text{mV}$

S. No	Frequency (Hz)	Output Voltage (V ₀)	Voltage Gain (A _v)=V _o /V _i .	Gain in dB A _v =20log(V _o /V _i)
1	50			
2	100			
3	300			
4	500			
5	700			
6	1K			
7	3K			
8	5K			
9	7K			
10	10K			
11	30K			
12	50K			
13	70K			
14	100K			
15	300K			
16	500K			
17	700K			
18	1MHz			

PROCEDURE:

1. Connect the circuit as shown in figure.
2. Apply supply voltage $V_{cc}=12\text{V}$
3. Keep $V_i=20\text{mV}$ by keeping frequency of function generator at 1kHz.
4. Keep input constant throughout the experiment.
5. Vary the input frequency 50 Hz to 1MHz and note down the output voltage.
6. Calculate the gain of the amplifier in decibels using the formula gain in $\text{dB}=20\log(V_o/V_i)$.
7. Plot the graph between frequencies Vs Gain.

RESULT:

11a. SERIES FED CLASS-A POWER AMPLIFIER

Exp. No:

Date:

AIM: To design a series fed class-A power amplifier in order to achieve max output ac power and efficiency using hardware.

COMPONENTS REQUIRED:

- | | |
|---|------------|
| 1. Transistor (NPN, Si) BC 107 | : 1 Nos. |
| 2. Electrolytic Capacitor 100 nF | : 2 Nos. |
| 3. Carbon film Resistors 1 k Ω , 33 Ω and 20 k Ω : | 1 No. each |

MEASURING INSTRUMENTS:

- | | |
|--------------------------|----------|
| 1. 20 MHz Dual trace CRO | : 1 No. |
| 2. Multimeter | : 2 Nos. |

MISCELLANEOUS:

- | | |
|---------------------------|---------|
| 1. Power Supply 0-30 V DC | : 1 No. |
| 2. Bread Board | : 1 No. |
| 3. Connecting Wires | : 1 Set |

CIRCUIT DIAGRAM:

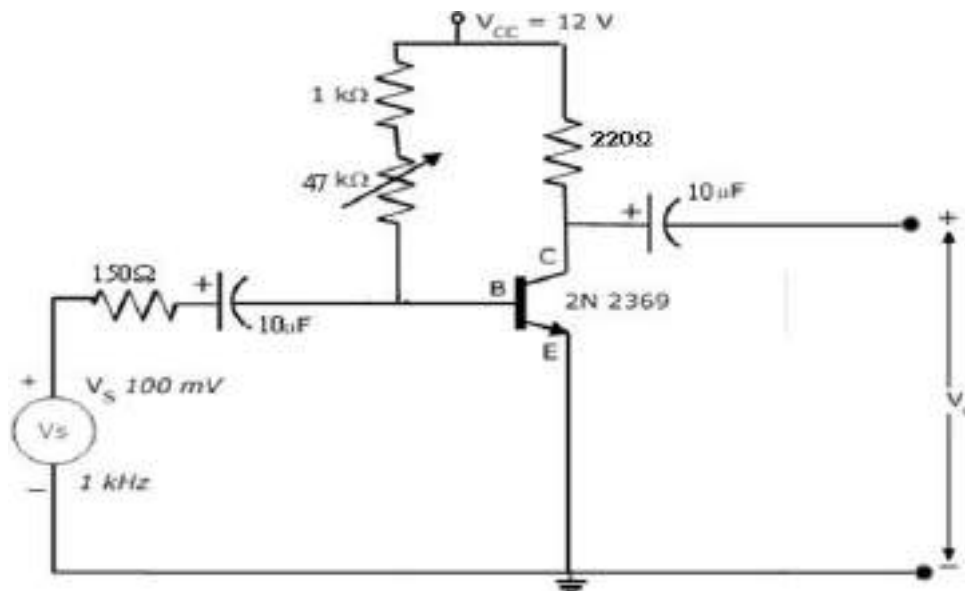

TABULAR FORM:

$V_{in}=100\text{ mV}$

Applied frequency	Output voltage(V_0)	Gain in dB= $20\log(V_0/V_i)$
1kHz		

THEORY:

The circuit is called “series fed” because the load R_L is connected in series with transistor output. It is also called as direct coupled amplifier. I_{CQ} =Zero signal collector current V_{CEQ} =Zero signal collector to emitter voltage power amplifiers are mainly used to deliver more power to the load. To deliver more power it requires large input signals, so generally power amplifiers are preceded by a series of voltage amplifiers. In class-A power amplifiers, Q-point is located in the middle of DC- load line. So output current flows from complete cycle of input signal. Under zero signal condition, maximum power dissipation occurs across the transistor. As the input signal amplitude increases power dissipation reduces. The maximum theoretical efficiency is 25%.

CALCULATIONS:

Take $R_L=R_C=220 \Omega$

1. DC input power $P_{DC} = V_{CC} \times \frac{V_{o(p-p)}}{R_L \times \pi} = \text{-----}$

2. AC output power $P_{AC} = \frac{(V_{o(p-p)})^2}{8R_L} = \text{-----}$

3. Efficiency $\eta = \frac{P_{AC}}{P_{DC}} \times 100 = \text{-----}$

PROCEDURE

1. Connect the circuit diagram and supply the required DC supply.
2. Apply the Ac signal at the input and keep the frequency at 1 kHz and connect the power output meter at the output. Change the load resistance in steps for each value of impedance and note down the output power.
3. Plot the graph between o/p power and load impedance. From this graph find the impedance for which the o/p power is maximum. This is the value of optimum load.
4. Select load impedance which is equal to 0 V or near about the optimum load. See the waveform of the o/p of the CRO.
5. Calculate the power sensitivity at a maximum power o/p using the relation.

The maximum input signal amplitude which produces undistorted output signal is _____.

The practical efficiency of the circuit is _____.

RESULT:

VIVA –VOCE QUESTIONS:

1. Differentiate between voltage amplifier and power amplifier?
2. Why power amplifiers are considered as large signal amplifier?
3. When does maximum power dissipation happen in this circuit?
4. What is the maximum theoretical efficiency?
5. Sketch waveform of output current with respective input signal?
6. What are the different types of class-A power amplifiers available?
7. What is the theoretical efficiency of the transformer coupled class-A power amplifier?
8. What is the difference in AC and DC load line?
9. How do you locate the Q-point?
10. What are the applications of class-A power amplifier?

11b. SERIES FED CLASS-A POWER AMPLIFIER (Using Simulation)

Exp. No:

Date:

PRELAB:

Study the classification and operation of Small signal and large signal amplifier.

OBJECTIVE:

To observe input and output power of class A Power amplifier, and also calculate Bandwidth.

SIMULATION TOOL:

- Multisim

APPARATUS:

S. No	Name	Range / Value	Quantity
1	D.C Regulated Power Supply	(0 – 30V)	1
2	Resistors	100K, 560Ω, 470Ω	1
3	Capacitors	2.2μF ,100uF	1
5	Inductor	1mH	1
6	CRO	--	1
7	Watt meters	--	2

THEORY:

The amplifier is said to be class A power amplifier if the q point and the input signal are selected such that the output signal is obtained for a full input cycle. For this class the position of q point is approximately at the mid-point of the load line. For all the values of input signal the transistor remains in the active region and never entire into the cutoff or saturation region. The collector current flows for 360° (life cycle) of the input signal in other words the angle of the collector current flow is 360° the class a amplifiers or furthers classified as directly coupled and transformer coupled and transformer coupled amplifiers in directly coupled type .The load is directly connected in the collector circuit while in the transformer coupled type, the load is coupled to the collector using the transformer.

Advantages:

1. Distortion analysis is very important
2. It amplifies audio frequency signals faithfully hence they are called as audio amplifiers

CIRCUIT DIAGRAM:

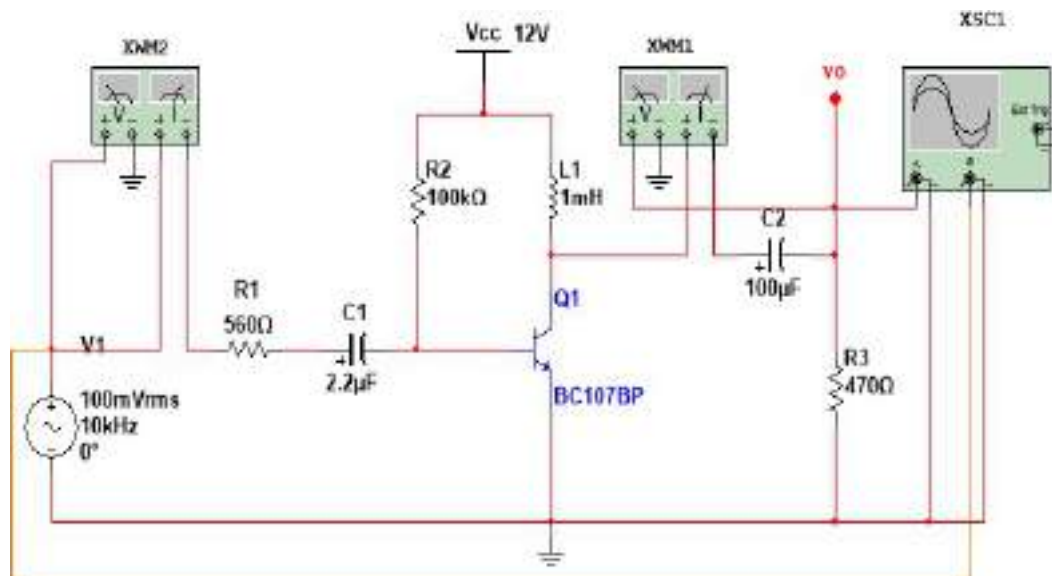

Observations and Graphs:

Input and Output waveforms

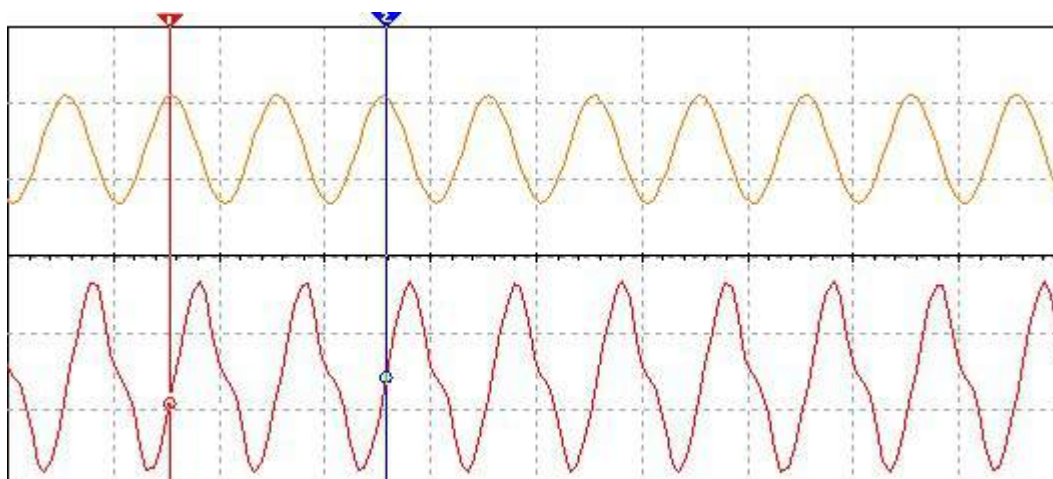

Disadvantages:

1. H parameter analysis is not applicable
2. Due to large power handling the transistor is used power transistor which is large in size and having large power rating

PROCEDURE:

1. Enter in to the Multisim 2013 software.
2. Customize the screen and then draw the circuit on the screen with the help of mouse.
3. Connect the WATTMETERS on both input and output side.
4. The input terminal is connected to one terminal of CRO and output to other terminal.
5. Start the simulation and observe the input and output waveforms.
6. Note down the values of input and output powers from Watt meters.

CALCULATIONS:

Efficiency (P_{ac} / P_{DC}) = _____

$$P_{ac} = V_{cc}I_c ; P_{DC} = V_m/2R_L = V_{pp}^2/8R_L$$

$$\% \eta = P_{ac} / P_{DC} \times 100$$

RESULT & DISCUSSION:

Frequency and Phase response:

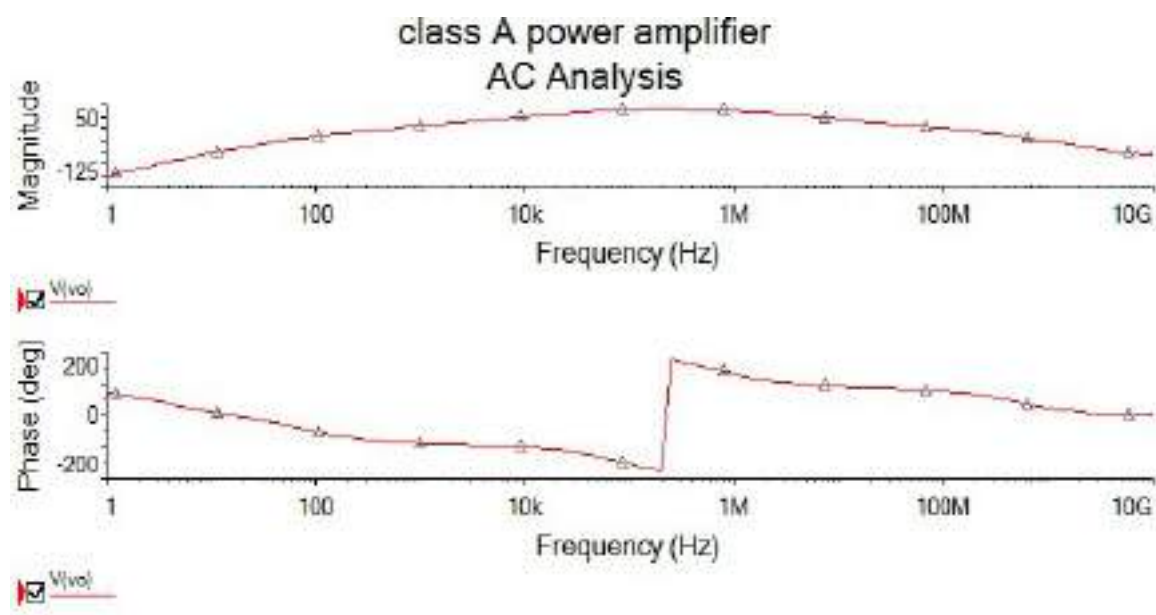

Review Questions:

1. Explain the operation of Class A power amplifier?
2. What are the advantages of Class A Power amplifier?
3. What is the efficiency of Class A power amplifier?
4. What is the difference between Small and Large signal Amplifiers?

12a. CLASS-B PUSH PULL AMPLIFIER

Exp. No:

Date:

AIM: To PSet the Graph between Load and Power of a Class B Push pull Power Amplifier.

APPARATUS:

1. Push pull power amplifier module	--	1
2. D.C Regulated Power supply (0-30V).	--	1
3. Function generator	--	1
4. CRO	--	1

CIRCUIT DIAGRAM:

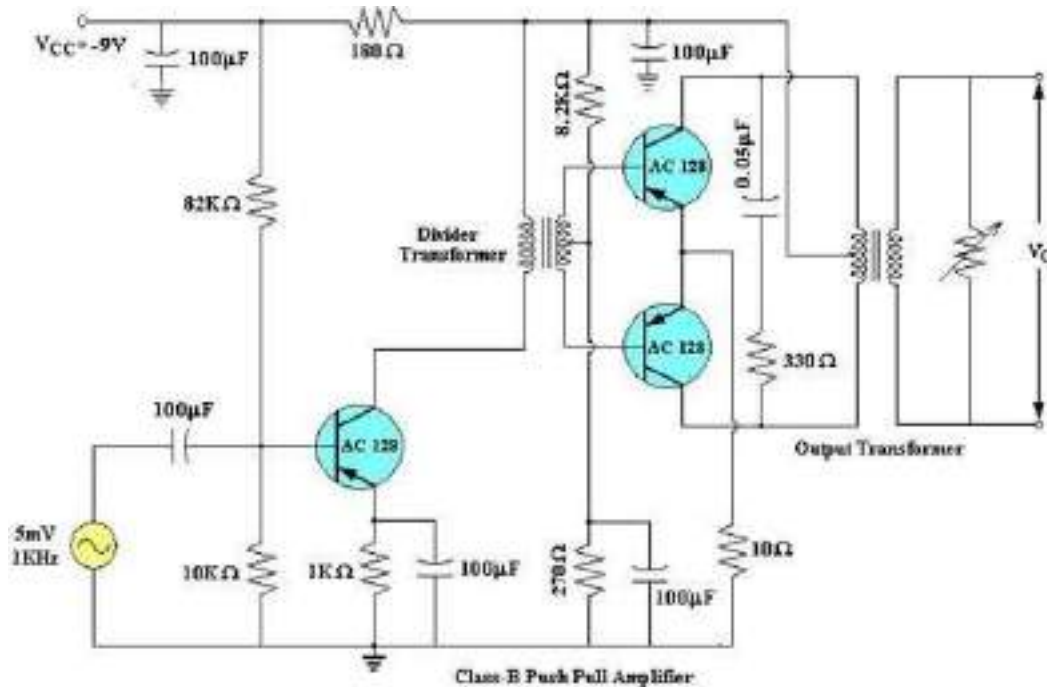

MODEL GRAPH:

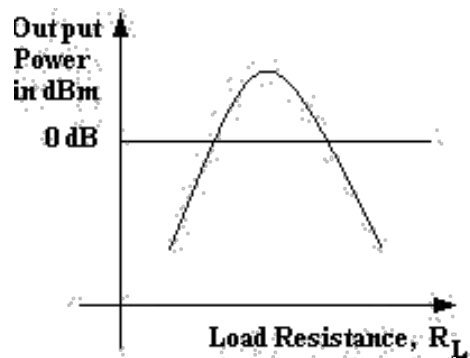

TABULAR FORM:

S. No	R_L ()	Output Power P_o (mW)	Power in db ($10 \log P_o$)

PROCEDURE:

1. Connect the circuit diagram as shown in the figure.
2. Determine the maximum signal handling capacity of the push pull amplifier.
3. Apply sinusoidal signal of 4mV peak to peak voltage at a frequency of 1 kHz.
4. Connect Power meter at the O/P terminals.
5. By changing the load at the O/P terminals measure the power in the Power meter.
6. Tabulate the readings.
7. pSet the graph between Power vs load

RESULT:**VIVA QUESTIONS:**

1. What is meant by conversion efficiency? Which type of power amplifier has the maximum conversion efficiency? Why?
2. To which class does the push-pull amplifier belongs and what are the advantages of it?
3. What is meant by crossover distortion? In which power amplifier it is maximum?
4. Why class-A amplifier is used in transmitter modulators?
5. What is the maximum theoretical efficiency of a class-A amplifier?
6. Which harmonics are eliminated in the class –B push-pull amplifier?
7. What is meant by complementary symmetry push-pull amplifier? State its advantages.
8. Why the load is to be coupled through a transformer in a class-A amplifier?
9. Discuss the stability techniques of power amplifier?
10. Draw the thermal equivalent circuit of a power amplifier?

12b. CLASS-B POWER AMPLIFIER

Exp. No:

Date:

PRELAB:

Study the operation of Class B Power amplifier

Identify various distortions occurred in Class B

Identify the different ways to avoid Distortions in class B power amplifier

OBJECTIVE:

To observe input and output power of class B Power amplifier, and also calculate Bandwidth.

SIMULATION TOOL:

- Multisim

APPARATUS:

S. No	Name	Range / Value	Quantity
1	D.C Regulated Power Supply	(0 – 30V)	1
2	Resistors	32Ω	4
4	Capacitors	100uF, 0.5mf	2,1
5	CRO	Dual channel	1
6	Watt meters	--	2

THEORY:

An amplifying system consists of several stages in cascade. The input and the intermediate stages amplify small signal excitations to a value large enough to drive the final device .The output stage feeds the final device .The output stage feeds a transducer such as a CRO, loudspeaker or servomotor. Thus the final stage must be capable of delivering a large voltage or current or appreciable amount of power. This requires an amplifier which is referred as a power amplifier

In class B complimentary symmetry class _B amplifier one n-p-n and p-n-p is used. Hence the circuit is called class-B complimentary symmetry amplifier. This circuit is transformer less circuit .But with common collector configuration it becomes transformer less Circuit to transfer maximum power to load. Hence the matched pair of complementary transistors are used in common collector configuration this is because in common collector configuration has Highest input impedance and lowest output impedance and hence the impedance matching is possible.

CIRCUIT DIAGRAM:

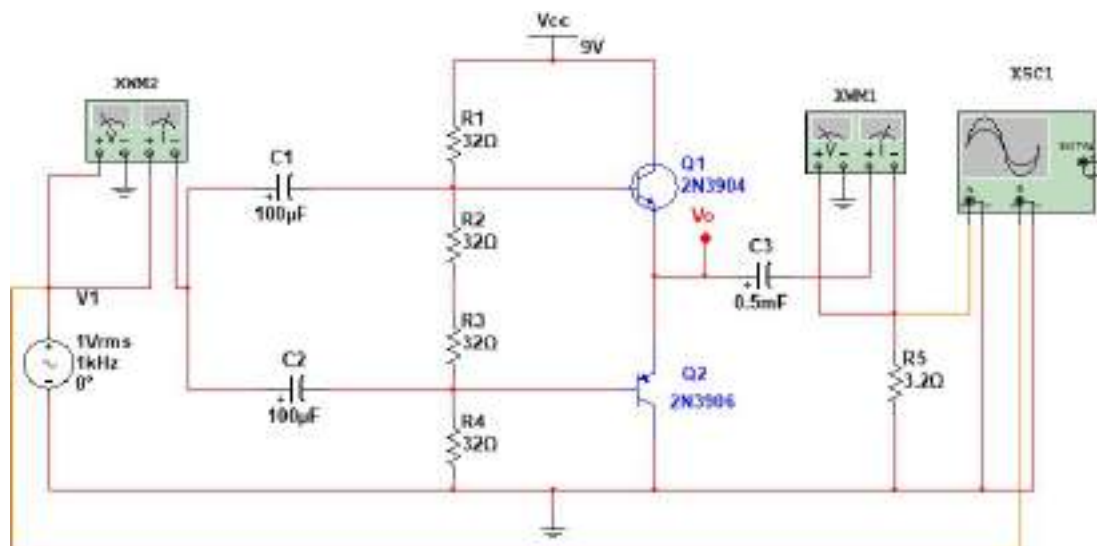

Class B Complementary Symmetry Power Amplifier

OBSERVATIONS:

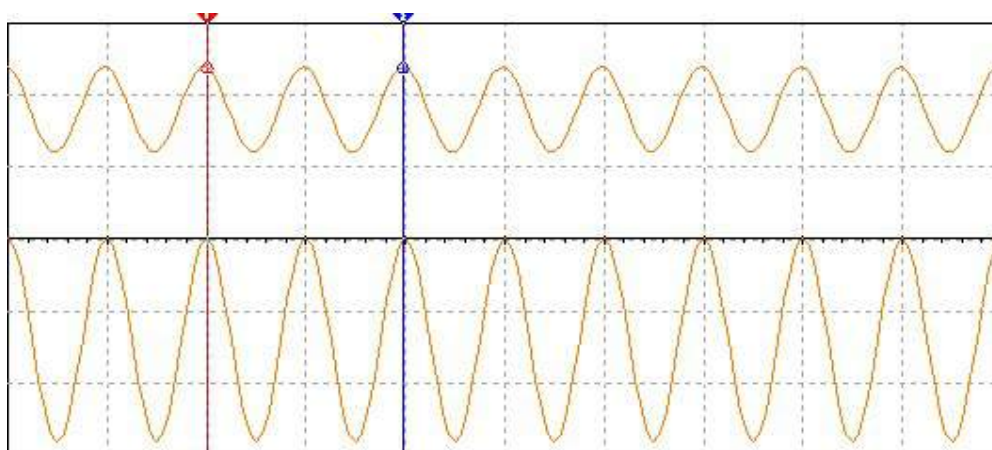

Input and output waveforms

PROCEDURE:

1. Enter in to the Multisim 2013 software.
2. Customize the screen and then draw the circuit on the screen with the help of mouse.
3. Connect Two Wattmeter and CRO on both input and output side.
4. The input terminal is connected to one terminal of CRO and output to other terminal.
5. Start the simulation and observe the input and output waveforms.
6. Note down the values of V_O & V_I and find AC and DC power.
7. Hence find efficiency

OBSERVATION: $V_O =$ $V_{CC} =$ $V_m = V_{pp}/2$ $R_L =$
Efficiency: $\frac{P_{ac}}{P_{dc}} = \frac{V_m \pi}{4V_{cc}}$
RESULT & DISCUSSION:

Frequency response:

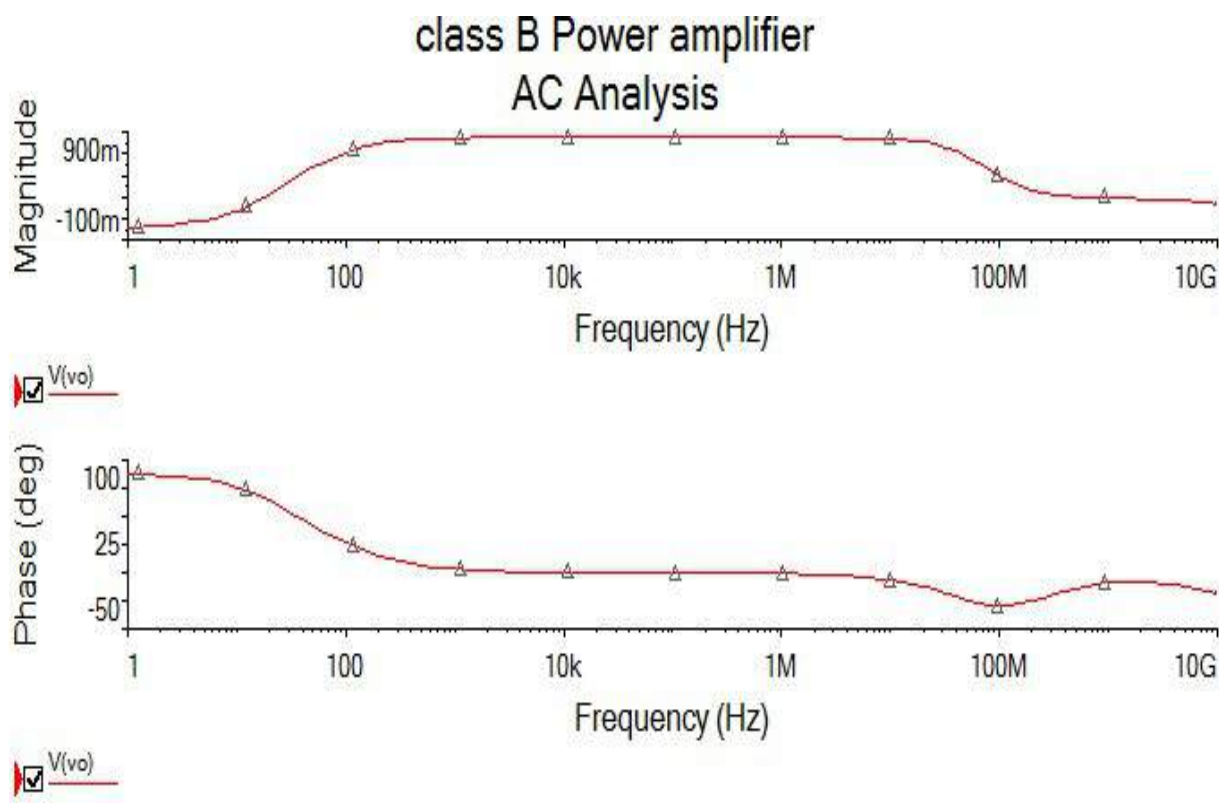
**REVIEW QUESTIONS:**

1. What is the efficiency of Class B complimentary symmetry power amplifier?
2. What are the advantages of Class B complimentary symmetry power amplifier?
3. What are the disadvantages in Class B push pull power amplifier?

13a. COMPLEMENTARY-SYMMETRY CLASS-B POWER AMPLIFIER

Exp. No:

Date:

AIM: To design a complementary-symmetry class-B push-pull power amplifier in order to achieve maximum output AC power and efficiency.

COMPONENTS REQUIRED:

1. Complementary-Symmetry Class-B Power Amplifier Trainer Module

MEASURING INSTRUMENTS:

1. CRO (Dual channel) DC – 20 MHz
2. Function generator : 1 No.

MISCELLANEOUS:

1. Connecting cards : 1 Set.

CIRCUIT DIAGRAM:

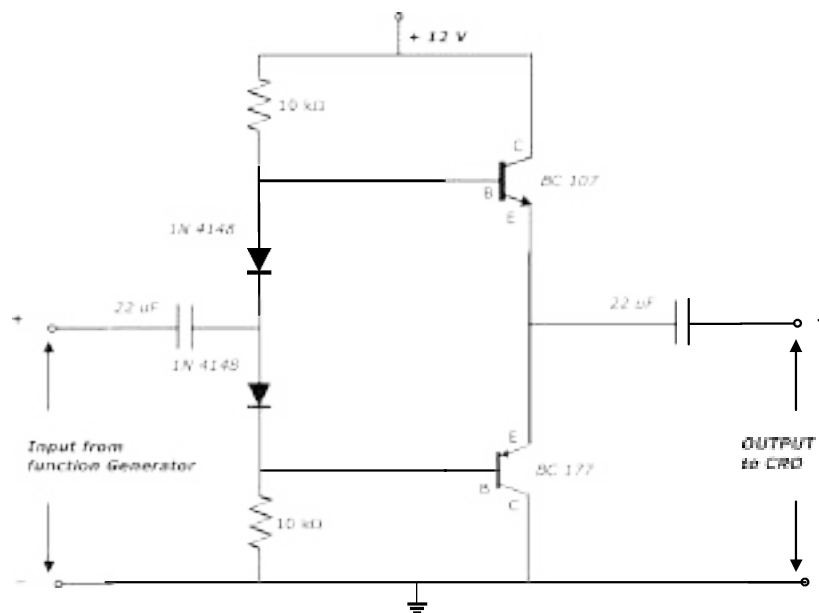

OUTPUT WAVEFORM:

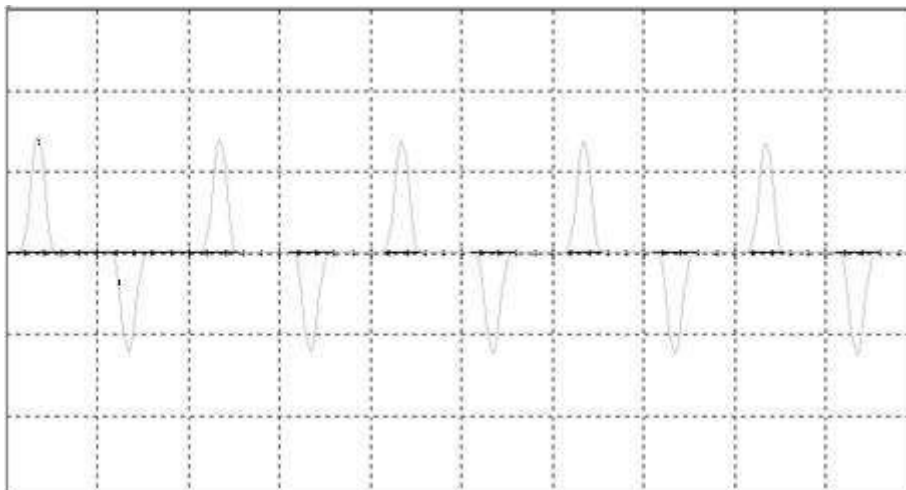

THEORY:

Power amplifiers are designed using different circuit configuration with the sole purpose of delivering maximum undistorted output power to load. Push-pull amplifiers operating either in class-B or class-AB are used in high power audio system with high efficiency.

In complementary-symmetry class-B power amplifier two types of transistors, NPN and PNP are used. These transistors act as emitter follower with both emitters connected together.

In class-B power amplifier Q-point is located either in cut-off region or in saturation region. So, that only 180° of the input signal is flowing in the output.

In complementary-symmetry power amplifier, during the positive half cycle of input signal NPN transistor conducts and during the negative half cycle PNP transistor conducts. Since, the two transistors are complement of each other and they are connected symmetrically so, the name complementary symmetry has come.

Theoretically efficiency of complementary symmetry power amplifier is 78.5%.

PROCEDURE:

1. Connect the circuit as shown in the circuit diagram.
2. Measure base, emitter and collector D.C voltages of both transistors and compare against estimated values.
3. Apply the input at input terminals of the circuit from the function generator.
4. Keep the input signal at constant frequency under mid frequency region and adjust the amplitude such that output voltage is undistorted.
5. Calculate the power efficiency and compare it with theoretical efficiency.

OBSERVATIONS:

Efficiency is defined as the ratio of AC output power to DC input power

DC input power = $V_{CC} \times I_{CQ}$; AC output power = $V_P \cdot P^2 / 8R_L$

CALCULATIONS:

Input DC power = $V_{CC} \times I_{CQ}$;

Output AC power = $V_{rms} \times I_{rms} = V_{PP}^2 / 8R_L$,

$$\eta = \frac{\text{Output AC power}}{\text{Input DC power}}$$

RESULT:

The maximum input signal amplitude which produces undistorted output signal is -----

The practical efficiency of the circuit is _____

VIVA VOCE QUESTIONS:

1. Differentiate between voltage amplifier and power amplifier.
2. Explain impedance matching provided by transformer.
3. Under what condition power dissipation is maximum for transistor in this circuit?
4. What is the maximum theoretical efficiency?
5. Sketch current waveform in each transistor with respective input signal.
6. How do you test matched transistors required for this circuit with DMM?
7. What is the theoretical efficiency of the complementary stage amplifier?
8. How do you measure DC and AC output of this amplifier?
9. Is this amplifier working in class A or B.?
10. How can you reduce cross over distortion?

13b. COMPLEMENTARY-SYMMETRY CLASS-B POWER AMPLIFIER (Using Simulation)

Exp. No:

Date:

AIM: To design a complementary-symmetry class-B push-pull power amplifier in order to achieve maximum output AC power and efficiency by using Simulation software

CIRCUIT DIAGRAM:

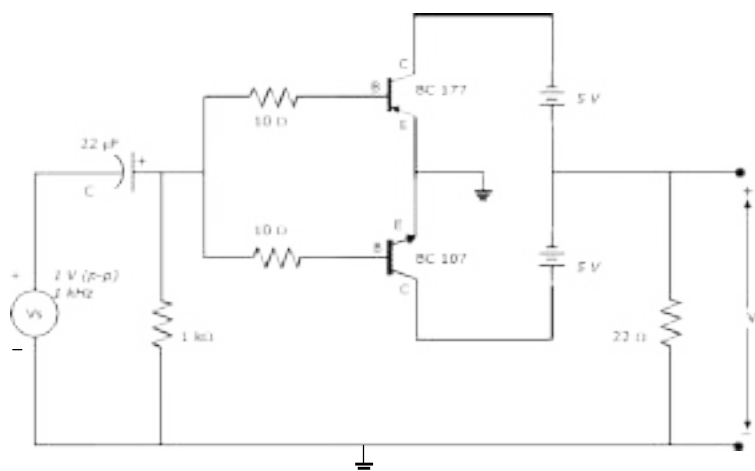

OUTPUT WAVEFORM:

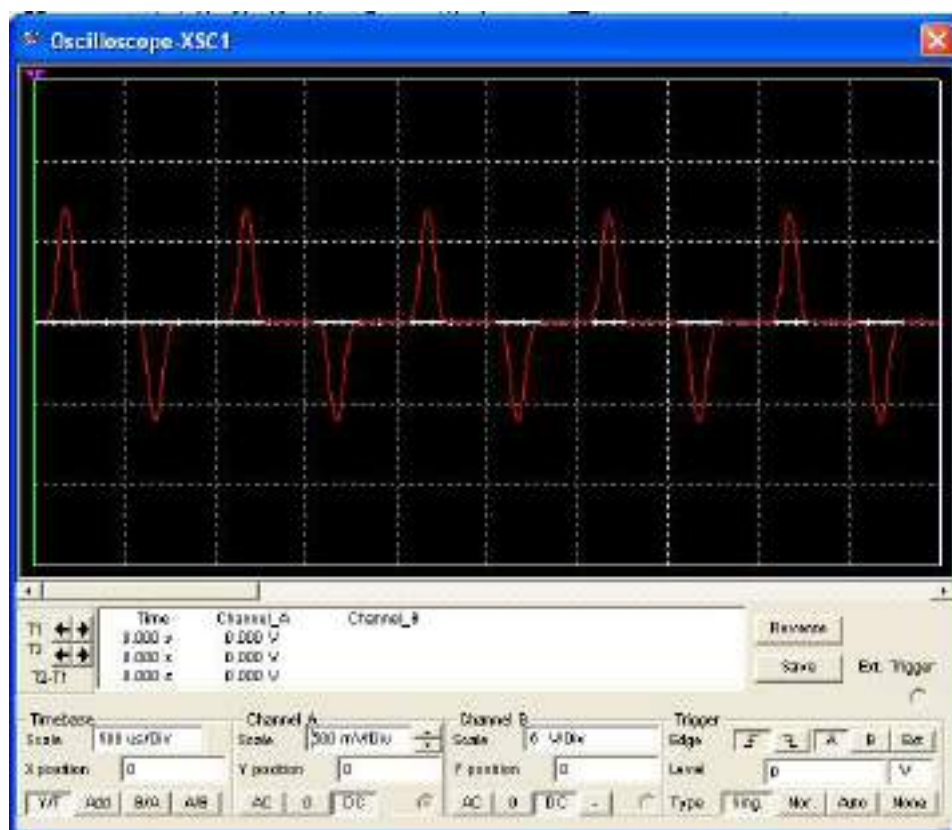

THEORY:

Power amplifiers are designed using different circuit configuration with the sole purpose of delivering maximum undistorted output power to load. Push-pull amplifiers operating either in class-B or class-AB are used in high power audio system with high efficiency.

In complementary-symmetry class-B power amplifier two types of transistors, NPN and PNP are used. These transistors act as emitter follower with both emitters connected together.

In class-B power amplifier Q-point is located either in cut-off region or in saturation region. So, that only 180° of the input signal is flowing in the output.

In complementary-symmetry power amplifier, during the positive half cycle of input signal NPN transistor conducts and during the negative half cycle PNP transistor conducts. Since, the two transistors are complement of each other and they are connected symmetrically so, the name complementary symmetry has come.

Theoretically efficiency of complementary symmetry power amplifier is 78.5%.

PROCEDURE:

1. Connect the circuit as shown in the circuit diagram.
2. Connect the signal generator output to input terminals of the circuit and Channel – 1 of dual trace CRO.
3. Connect the output terminal of the circuit to Channel – 2 of the dual trace CRO.
4. Set the signal generator output at 1 V sine wave at 1 kHz constant and feed it to the circuit.
5. Simulate the circuit and observe the output waveform

OBSERVATIONS:

Efficiency is defined as the ratio of AC output power to DC input power

$$\text{DC input power} = V_{CC} \times I_{CQ} \quad \text{AC output power} = \frac{V_{P-P}^2}{8RL}$$

CALCULATIONS

$$\text{Input DC power} = V_{CC} \times I_{CQ}$$

$$\text{Output AC power} = V_{rms} \times I_{rms} = \frac{V_{PP}^2}{8RL}, \quad \eta = \frac{\text{Output AC power}}{\text{Input DC power}}$$

RESULT:

The maximum input signal amplitude which produces undistorted output signal is _____

The practical efficiency of the circuit is _____

14a. BOOTSTRAP EMITTER FOLLOWER

Exp. No:

Date:

AIM: To construct a bootstrap sweep circuit and generate a ramp voltage and to measure sweep time T_S , return time T_{pr} .

COMPONENTS REQUIRED:

- | | |
|---|--------------|
| 1. Transistors SL 100 (Si) | : 2 Nos. |
| 2. Diode 1N 4007 (Si): 1 No. | |
| 3. Ceramic Disc Capacitor 100 μ F, 10 nF | : 1 No. each |
| 4. Electrolytic Capacitor 47 μ F | : 1 No. each |
| 5. Carbon film Resistors 0.25 W 100 k Ω , 10 k Ω and 15 k Ω : 1 No. each | |

MEASURING INSTRUMENTS:

- | | |
|------------------------------------|---------|
| 1. 20 MHz Cathode Ray Oscilloscope | : 1 No. |
|------------------------------------|---------|

MISCELLANEOUS:

- | | |
|---|---------|
| 1. 1 MHz Signal generator | : 1 No. |
| 2. Regulated DC power supply (0-30 V) : 1 No. | |
| 3. Bread board Trainer Module | : 1 No. |
| 4. Connecting wires | : 1 Set |

CIRCUIT DIAGRAM:

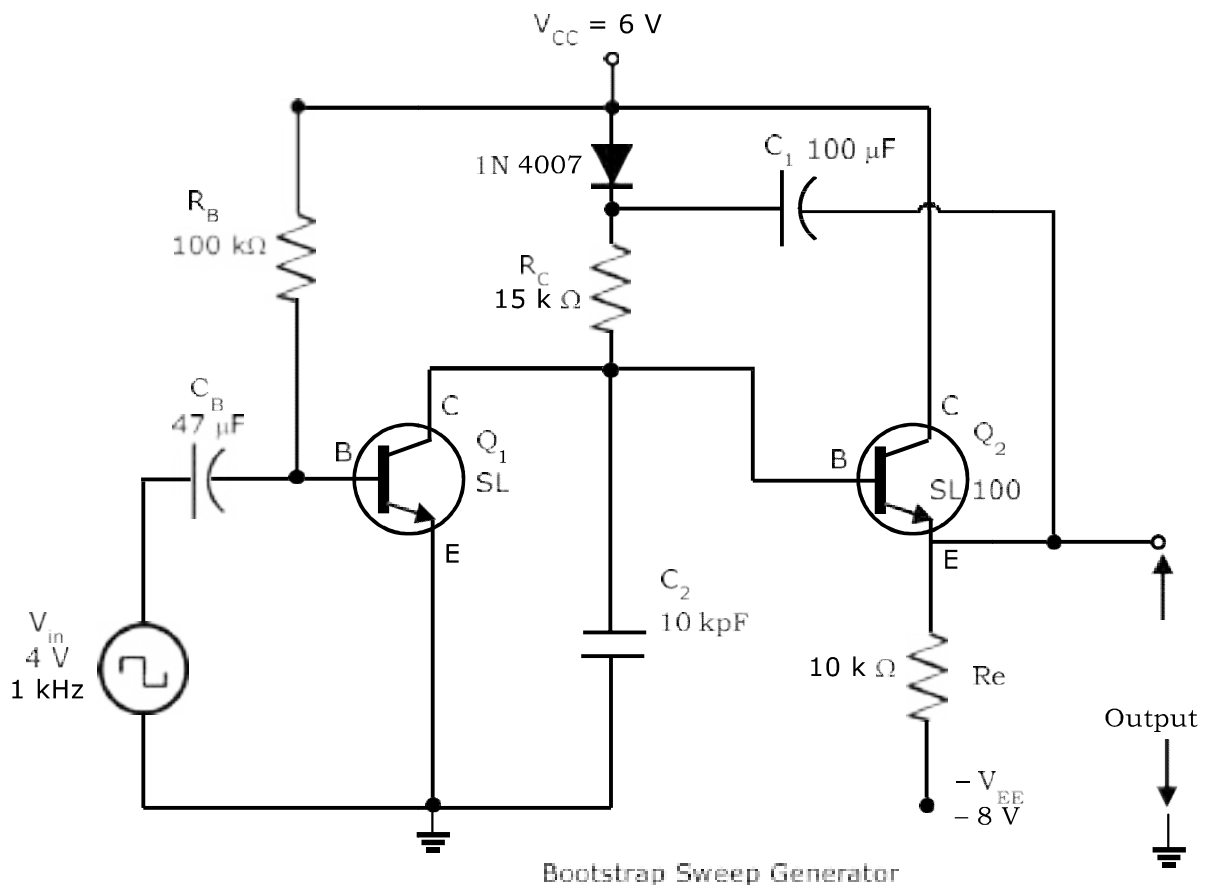

THEORY:

The bootstrap sweep generator uses the following principle in its functioning and generates the ramp voltage: The transistor Q_1 acts as ON-OFF switch. Q_2 is emitter follower. Input V_i is a pulse voltage or rectangular wave. When input V_i is positive transistor Q_1 becomes ON i.e. it goes into saturation. Emitter of Q_2 is coupled to collector of Q_1 through capacitor C_B .

When the input V_i goes negative, Q_1 becomes OFF, the potential at the collector terminal of Q_1 rises. This increase of voltage at this point is transmitted to B through Q_2 and capacitor C_B .

The result is that the potential of B also arises by the same amount. This is the principle of bootstrap.

PROCEDURE:

1. Rig-up the circuit on the bread board as per the circuit diagram.
2. Apply 6 V V_{CC} , 8 V V_{EE} from the dual channel DC regulated power supply.
3. Apply 4 V_{F-P} square wave from the function generator to the circuit and channel I of dual trace CRO.
4. Connect the circuit output to channel II of dual trace CRO.
5. Measure the peak to peak output ramp voltage, sweep time T_B , return time T_r from the output waveform.
6. Compare the practical values with the theoretical values.
7. Draw the input and output waveforms on the graph.

Observations

1. TS =

2. Tr =

3. Output ramp voltage (V) =

- 4. $V_{CE(sat)}$ $V_{BE(sat)}$ (V) =**RESULT:**

VIVA QUESTIONS

1. Explain the basic principle involved in bootstrap sweep generator.
2. Mention the type of feedback employed in bootstrap sweep generator.
3. Mention the characteristics of the amplifier used in bootstrap sweep generator.
4. What is input resistance of the bootstrapped amplifiers?
5. What does bootstrapping mean?
6. Why bootstrapping is done in a buffer amplifier?

14b. BOOTSTRAP EMITTER FOLLOWER (Using Simulation)

Exp. No:

Date:

AIM: To construct a bootstrap sweep circuit and generate a ramp voltage and to measure sweep time T_s , return time T_r using Simulation.

CIRCUIT DIAGRAM:

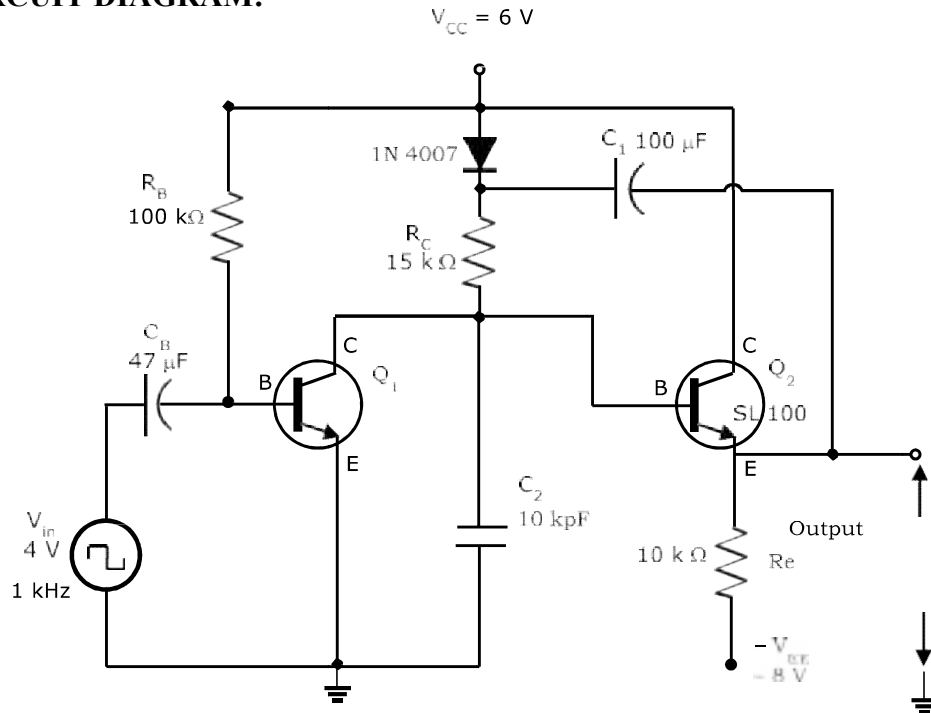

Bootstrap Sweep Generator

OUTPUT WAVEFORM:

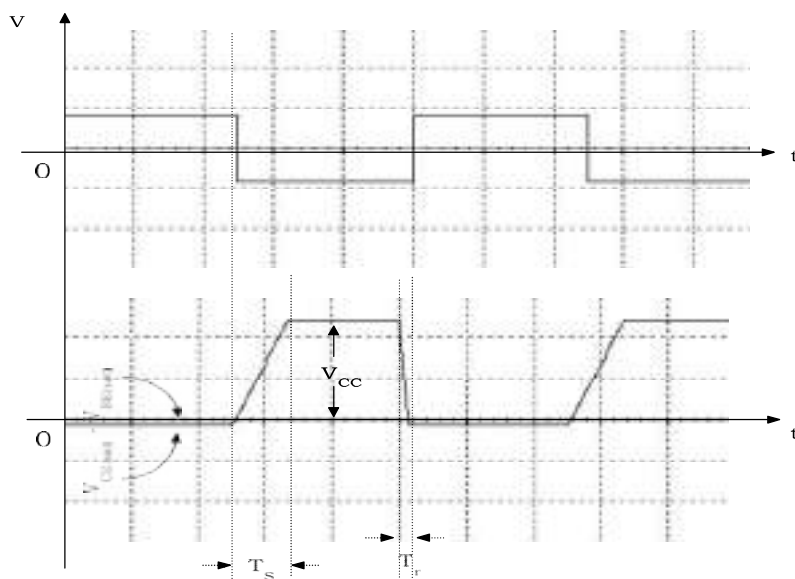

THEORETICAL CALCULATIONS

Sweep time = T_S , Return time = T_r ,

$$T_S = RC, R = 15 \text{ k}\Omega, C = 10 \text{ nF}$$

$$T_r = \frac{C_{VS}}{V_{CC} \left(\frac{h_{FE}}{R_E} - \frac{1}{R} \right)}$$

$$h_{FE} = 150$$

PROCEDURE

1. Rig-up the circuit on the bread board as per the circuit diagram.
2. Apply 6 V V_{CC} , 8 V V_{EE} from the dual channel DC regulated power supply.
3. Apply 4 V_{P-P} square wave from the function generator to the circuit and channel I of dual trace CRO.
4. Connect the circuit output to channel II of dual trace CRO.
5. Measure the peak to peak output ramp voltage, sweep time T_S , return time T_r from the output waveform.
6. Compare the practical values with the theoretical values.
7. Draw the input and output waveforms on the graph.

Observations

1. $T_S =$
2. $T_r =$
3. Output ramp voltage (V) =
4. $V_{CE(sat)} - V_{BE(sat)}$ (V) =

RESULT:

Simulation Procedure:

PROCEDURE for 2 stage RC Coupled Amplifier:

1. Connect the circuit as shown in the circuit diagram.
2. Connect the signal generator output to input terminals of the circuit and Channel – A of dual trace CRO.
3. Connect the output terminal of the circuit to Channel – B of the dual trace CRO.
4. Set the signal generator output at 10 mV sine wave at 1 kHz constant and fed it to the circuit.
5. In the Simulation tab go to analysis - AC analysis. Set the starting frequency as 20 Hz and Stop frequency 10 MHz, vertical scale as linear and no. of points per decade 1000.
6. In the output tab select Add expression write formula as $20*\log((V_O)/(V_i))$ in the expression field. Select OK and Simulate.
7. Select the cursers and find the FH and FL from the frequency response to find out the bandwidth.

PROCEDURE for Class –C Tuned amplifier:

1. Connect the circuit as shown in the circuit diagram.
2. Connect the output terminal of the circuit to Channel – A of the dual trace CRO.
3. In the Simulation tab go to analysis - AC analysis. Set the starting frequency as 10 kHz and Stop frequency 30 kHz, vertical scale as linear and no of points per decade equal to 1000 and simulate.
4. Select the cursers and find the FT from the frequency response to find out the tuned frequency.

PROCEDURE for RC Phase shift & Wein Bridge Oscillator:

1. Connect the circuit as shown in the circuit diagram.
2. Connect the output terminal of the circuit to Channel – 1 of the dual trace CRO.
3. Simulate, adjust the potentiometer (i.e., 12 k Ω variable resistance) to get the correct sine wave form. Place the both cursers in the CRO observe the T2– T1 as T.
4. PSet the graph for the obtained frequency

PROCEDURE for Shunt and Series Voltage Regulators:

1. Connect the circuit as shown in the circuit diagram.
2. Connect the output terminal of the circuit to Voltmeter.
3. In the Simulation tab go to analysis - DC Sweep. Set the starting value to 0 Volts and stop value 20 Volts, Steps 0.5 Volts and simulate.
4. Select the curser to find out the output voltage for the applied voltages. Note down the voltages in the respective tabular form i.e., V_{in} and V_{out} .
5. Repeat the step 4 for all the desired RL.
6. PSet the graph V_{in} Vs V_{out}

INTRODUCTION TO MULTISIM

Multisim is the schematic capture and simulation program designed for schematic entry, simulation, and feeding to downstage steps, such as PCB layout. It also includes mixed analog/digital simulation capability, and microcontroller co-simulation.

Ultiboard is used to design printed circuit boards, perform certain basic mechanical CAD operations, and prepare them for manufacturing. It also provides automated parts placement and layout.

Multisim User Interface: Multisim user interface includes the following elements:

Multisim User Interface

Multisim's user interface includes the following elements:

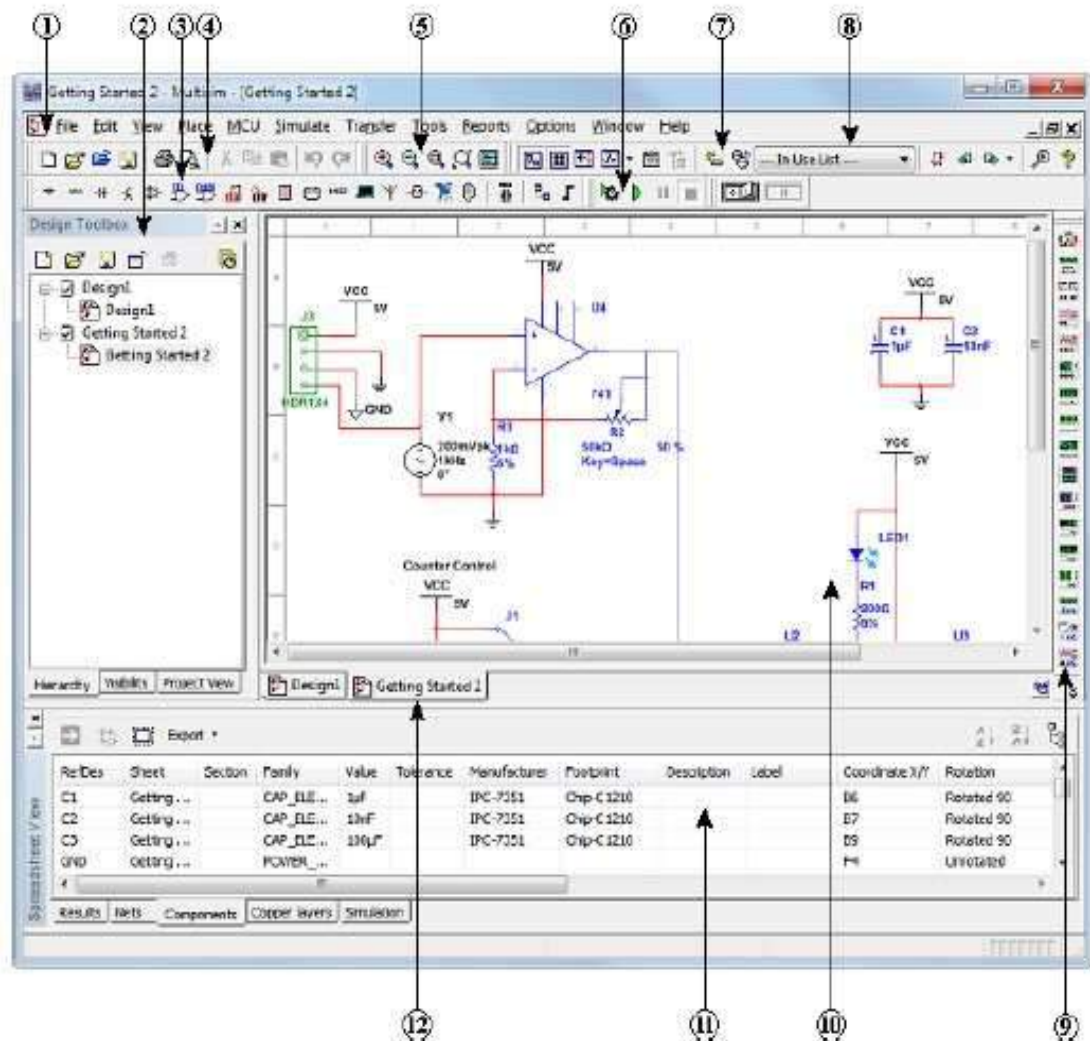

1	Menu Bar	5	View Toolbar	9	Instruments Toolbar
2	Design Toolbox	6	Simulation Toolbar	10	Workspace
3	Component Toolbar	7	Main Toolbar	11	Spreadsheet View
4	Standard Toolbar	8	In Use List	12	Active Tab

Refer to the table below as needed:

	Element	Description
1	Menu Bar	Contains the commands for all functions.
2	Design Toolbox	Use to navigate through the different types of files in a project (schematics, PCBs, reports), view a schematic's hierarchy and show or hide different layers.
3	Component toolbar	Contains buttons that you use to select components from the Multisim databases for placement in your schematic.
4	Standard toolbar	Contains buttons for commonly-performed functions such as Save, Print, Cut, and Paste.
5	View toolbar	Contains buttons for modifying the way the screen is displayed.
6	Simulation toolbar	Contains buttons for starting, stopping, and other simulation functions.
7	Main toolbar	Contains buttons for common Multisim functions.
8	In Use List	Contains a list of all components used in the design.
9	Instruments toolbar	Contains buttons for each instrument.
10	Workspace	This is where you build your designs.
11	Spreadsheet View	Use for fast advanced viewing and editing of parameters including component details such as footprints, RefDes, attributes and design constraints.
12	Active tab	Indicates the design you are working on. Click another tab to switch.

Schematic Capture

In the following sections, you will place and wire the components in the design shown below.

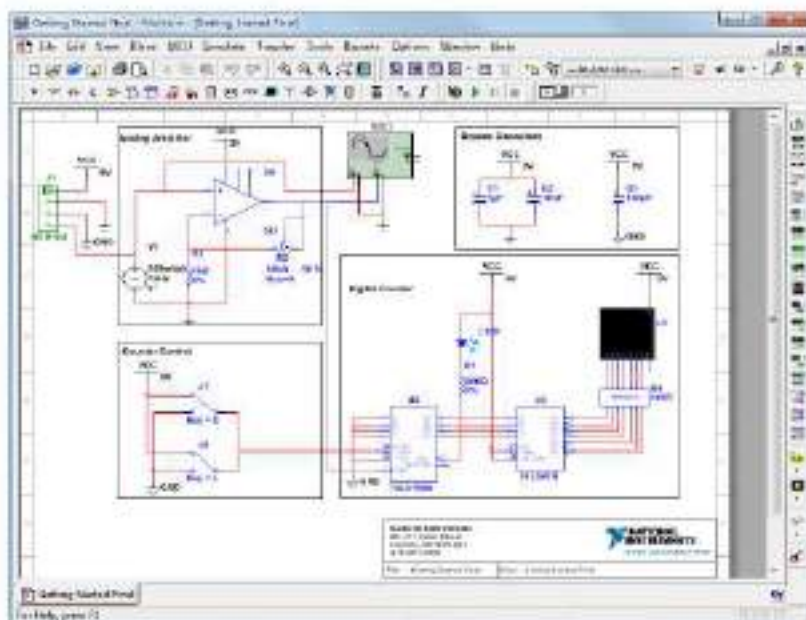

Creating the File

Complete the following steps to create the design file:

1. **Launch Multisim.**
A blank file called Design1 opens on the workspace.
2. **Select File>Save as** to display a standard Windows Save dialog.
3. **Navigate to the location where you wish to save the file, enter MyGettingStarted as the File name, and click the Save button.**

Placing the Components

Complete the following steps to place the components on *MyGettingStarted*:

1. Select **Place»Component** to display the **Select a Component** dialog box.
2. Select the **Indicators** component **Group** and the **HEX_DISPLAY** component **Family**.
3. Type `seven_seg_decimal_com_a_blue` in the **Component** field.

As you type, the string appears in the **Searching** field at the bottom of the browser. Matches display in the **Component** list.

4. Click **OK** when the desired component displays as shown below.

The component appears as a “ghost” on the cursor.

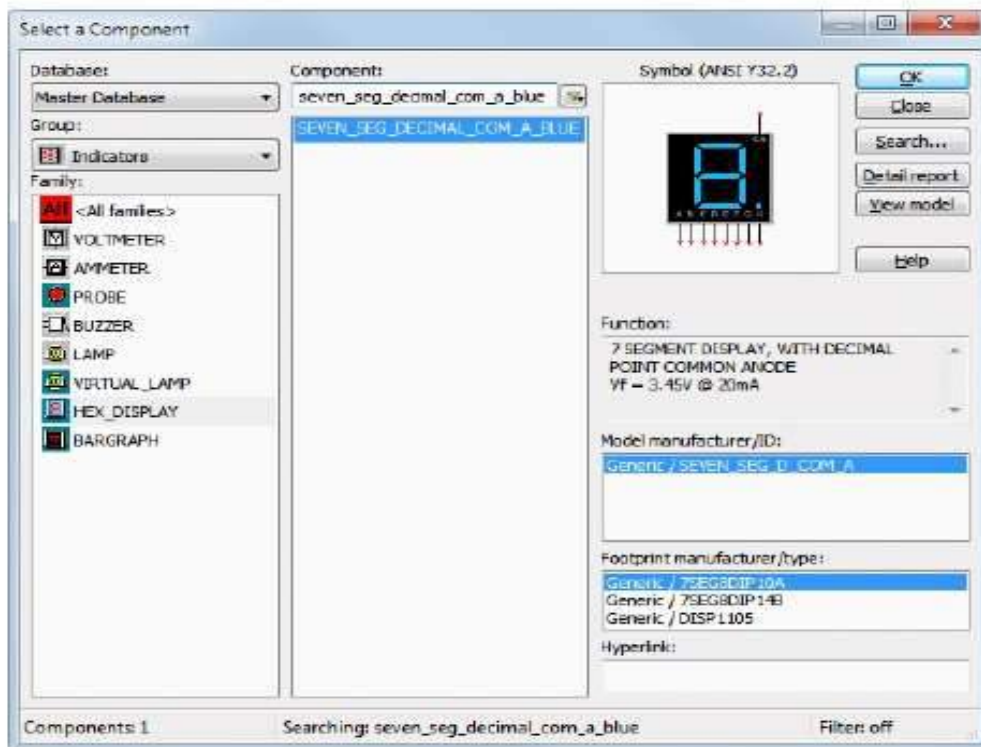

5. Move the cursor to the bottom-right of the workspace and click to place the component. Note that the Reference Designator for this component is **U1**.

6. Place the remaining components in the Digital Counter area as shown below.



Tip The Group and Family location of each component is listed in *Component Locations*.

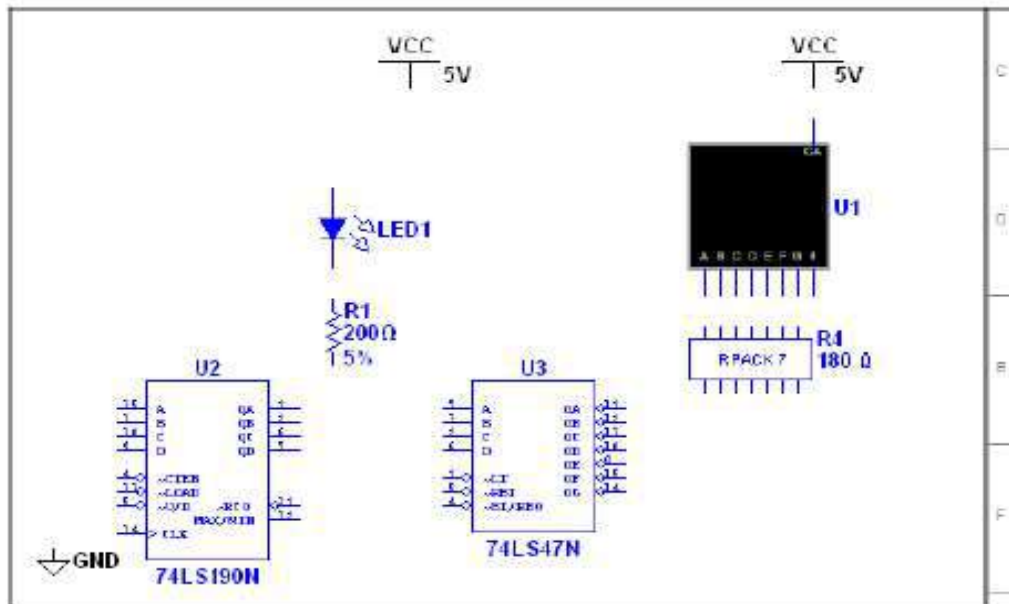

Tip While placing the 200 Ω resistor, press <Ctrl-R> to rotate it to a vertical orientation.

7. Place the components in the Counter Control section as shown below.

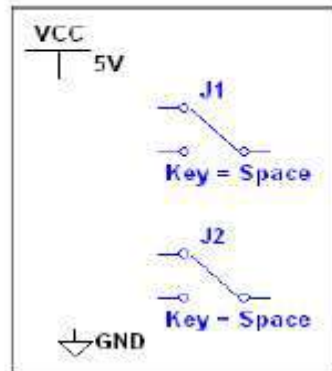

8. Right-click on each SPDT switch and select **Flip horizontally**.

9. Place the components in the Analog Amplifier section as shown below, rotating as needed.

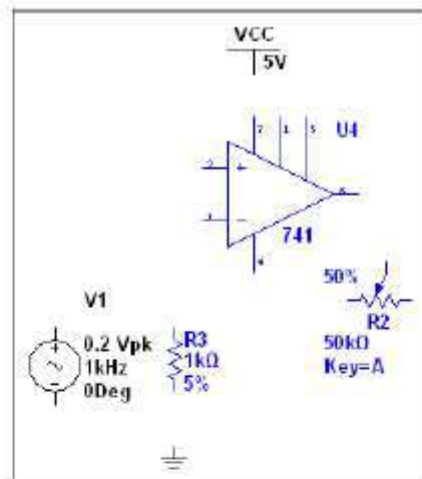

10. Double-click on the AC voltage source (V1), change Voltage (Pk) to 200 mV and click OK to close the dialog.
11. Place the components in the Bypass Capacitors section as shown below.

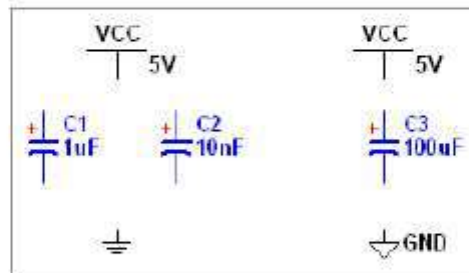

12. Place the header and associated components as shown below.

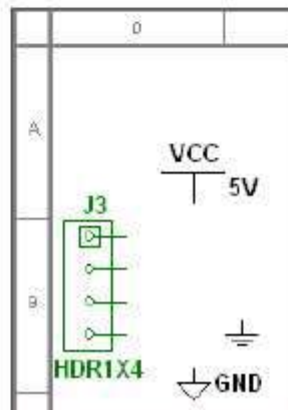

Component Locations

The following shows you where to locate all components for this design in the **Select a Component** dialog box.



Tip Reference Designators (for example, U1, U2) are assigned in the order the components are placed. If you place components in a different order than in the original design, the numbering will differ. This will not affect the operation of the design in any way.

Component	Group	Family
VCC GND - DGND GROUND	Sources	POWER_SOURCES
LED1 - LED_blue	Diodes	DIODES_VIRTUAL
U1 - 7-segment display	Indicators	HEX_DISPLAY
U2 - 74LS190N U3 - 74LS47N	TTL	74LS
R1 - 200 Ω	Basic	RESISTOR
R2 - 1 k potentiometer	Basic	POTENTIOMETER
R3 - 1 k	Basic	RESISTOR
R4 - 10Line_Bussed	Basic	RPACK
J1, J2 - SPDT	Basic	SWITCH
U4 - 741	Analog	OPAMP
V1 - AC_VOLTAGE	Sources	SIGNAL_VOLTAGE_SOURCES
C1 - 1 μ F C2 - 10 nF C3 - 100 μ F	Basic	CAP_ELECTROLIT
J3 - HDR1X4	Connectors	HEADERS_TEST

Wiring the Design

All components have pins that you use to wire them to other components or instruments. As soon as your cursor is over a pin, the pointer changes to a crosshair, indicating you can start wiring.



Tip You can wire the design that you placed on the workspace or you can use Getting Started 1 from the Getting Started folder (found inside the samples folder).

Complete the following steps to wire the design:

1. Click on a pin on a component to start the connection (your pointer turns into a crosshair) and move the mouse.

A wire appears, attached to your cursor.

2. Click on a pin on the second component to finish the connection.

Multisim automatically places the wire, which conveniently snaps to an appropriate configuration, as shown below.

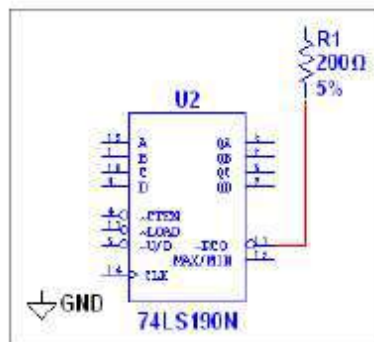

Tip You can also control the flow of the wire by clicking on points as you move the mouse. Each click “fixes” the wire to that point.

4. Finish wiring the design as shown below.

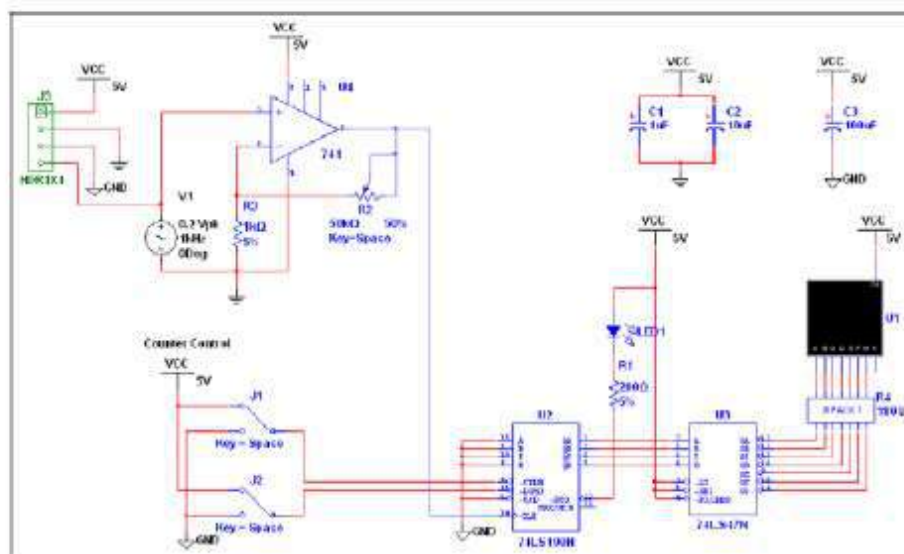

Simulation

Simulating your designs with Multisim catches errors early in the design flow, saving time and money.

Virtual Instrumentation

In this section, you will simulate the design and view the results with the virtual oscilloscope.



Tip You can also use Getting Started 2 from the Getting Started folder (found in the samples folder).

1. Set up the interactive keys for J1, J2 and R2:
 - a. Double-click on each and select the **Value** tab.
 - b. Select "E" for J1 and "L" for J2 in the **Key for toggle** field.
 - c. Select "A" in the **Key** field for R2.



Note J1, J2 and R2 are interactive components.

2. Press <E> to enable the counter.
Or
 Click on the widened switch arm that appears when you hover the cursor over J1.
 Enable is Active Low.
3. Select **Simulate»Instruments»Oscilloscope** to place the oscilloscope on the workspace.

Complete the following steps to create a BOM (bill of materials) for your design:

1. Select **Reports»Bill of Materials**.

The report appears, similar to this:

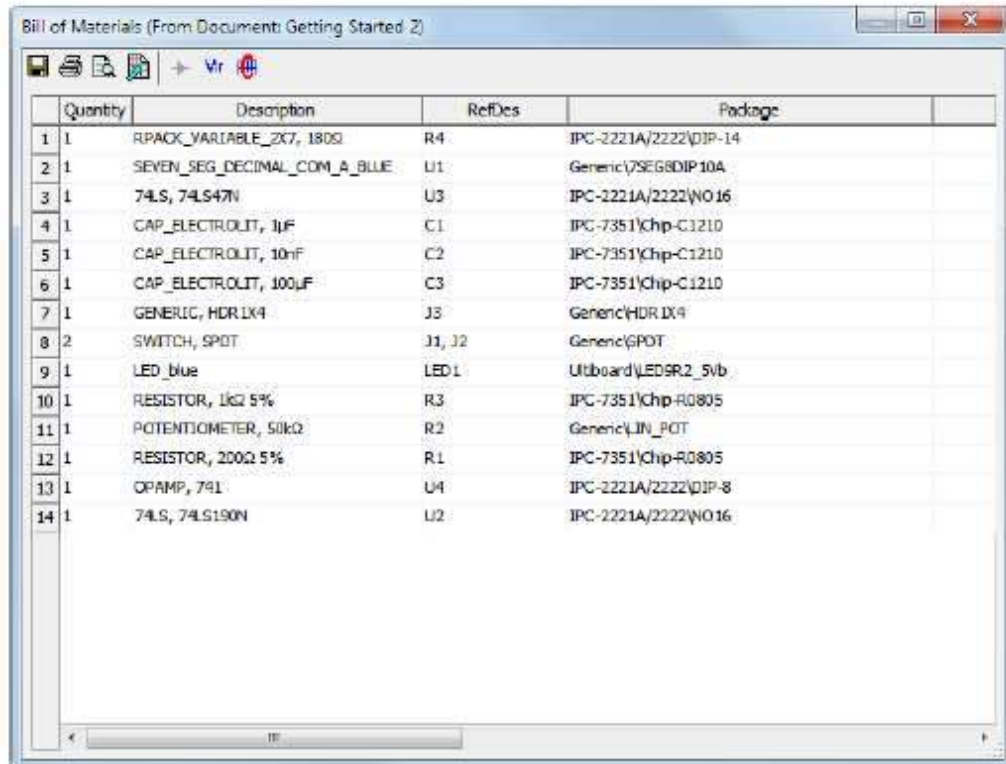

Quantity	Description	RefDes	Package
1	RPACK_VARIABLE_2K7, 180Ω	R4	IPC-2221A/2222/DIP-14
2	SEVEN_SEG_DECIMAL_COM_A_BLUE	U1	Generic/7SEG8DIP10A
3	74LS, 74LS47N	U3	IPC-2221A/2222/NO16
4	CAP_ELECTROLIT, 1μF	C1	IPC-7351/Chp-C1210
5	CAP_ELECTROLIT, 10nF	C2	IPC-7351/Chp-C1210
6	CAP_ELECTROLIT, 100μF	C3	IPC-7351/Chp-C1210
7	GENERIC, HDR1X4	J5	Generic/HDR1X4
8	SWITCH, SPDT	J1, J2	Generic/SPDT
9	LED_blue	LED1	Uitboard/LED9R2_5vb
10	RESISTOR, 1kΩ 5%	R3	IPC-7351/Chp-R0805
11	POTENTIOMETER, 50kΩ	R2	Generic/JN_POT
12	RESISTOR, 200Ω 5%	R1	IPC-7351/Chp-R0805
13	OPAMP, 741	U4	IPC-2221A/2222/DIP-8
14	74LS, 74LS190N	U2	IPC-2221A/2222/NO16

Click the **Send to printer** button to print the Bill of Materials. A standard **Print** dialog box appears, where you choose the printer, number of copies, and so on.



Click the **Save to text file** button to save the Bill of Materials. A standard Windows file save dialog box appears, where you specify the path and file name.



Because the Bill of Materials is primarily intended to assist in procurement and manufacturing, it includes only “real” components—it excludes components that are not real or available for purchase, such as sources or virtual components. Components without assigned footprints do not appear in the Bill of Materials.

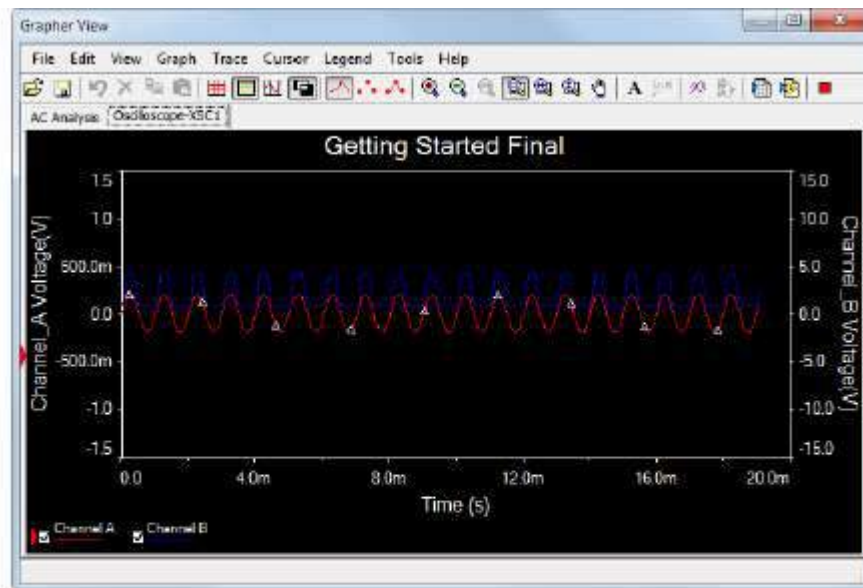

The Postprocessor

Use the **Postprocessor** to manipulate the output from analyses and plot the results on a graph or chart. Types of mathematical operations that can be performed on analysis results include arithmetic, trigonometric, exponential, logarithmic, complex, vector and logic.

Reports

You can generate a number of reports in Multisim: **Bill of Materials (BOM)**, **Component Detail Report**, **Netlist Report**, **Schematic Statistics**, **Spare Gates** and the **Cross Reference Report**.

The following section uses the **BOM** as an example for the tutorial design.

Bill of Materials

A bill of materials lists the components used in a design, providing a summary of the components needed to manufacture the circuit board.

Information provided for each component includes:

- quantity required.
- description, including the type of component (example: resistor) and value (example: 5.1 k Ω).
- Reference Designator.
- package or footprint name.

Analysis

In this section, you will use **AC Analysis** to verify the frequency response of the amplifier.

Complete the following steps to perform an **AC Analysis** at the output of the op-amp:

1. Double-click on the wire that is attached to pin 6 of the op-amp.
The **Net Properties** dialog box displays.
2. Change the **Preferred net name** to `analog_out`.
3. Select **Simulate»Analyses»AC analysis»Output** tab.
4. Highlight `V(analog_out)` in the **Variables in circuit** (left) column and click **Add**.
`V(analog_out)` moves to the **Selected variables for analysis** (right) column.
This indicates that the voltage at node `V(analog_out)` will be displayed after simulation.
5. Click **Simulate**.
The results of the analysis appear in the **Grapher**.

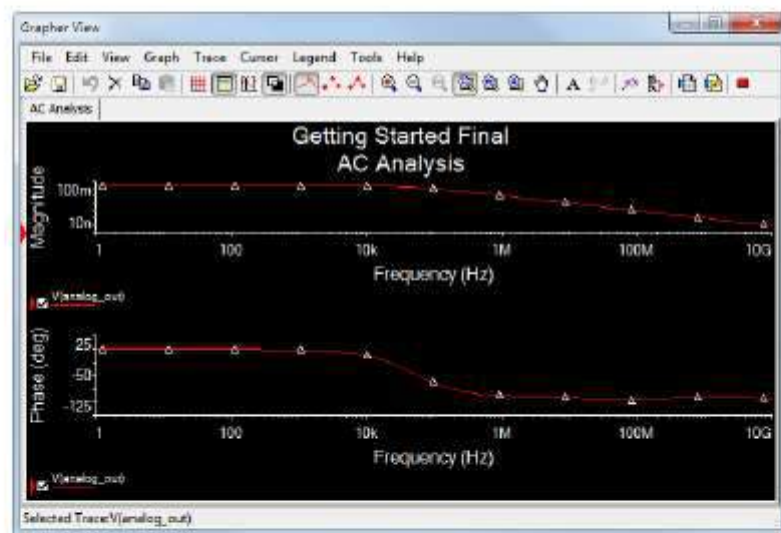

The Grapher

The **Grapher** is a multi-purpose display tool that lets you view, adjust, save and export graphs and charts. It is used to display the results of all Multisim analyses in graphs and charts, and graphs of traces for some instruments (for example, the oscilloscope).

Complete the following steps to view results of a simulation on the **Grapher**:

1. Run the simulation with the oscilloscope as described earlier.
2. Select **View»Grapher**.

4. Wire the instrument as shown in step 7.



Tip To differentiate between traces on the oscilloscope, right-click on the wire connected to the scope's **B** input and select **Segment color** from the context menu that displays. Select a color that differs from the wire connected to the **A** input, for example blue. (Changing wire color or performing other editing functions cannot be done while simulation is running).

5. Double-click on the oscilloscope icon to show its instrument face.
6. Select **Simulate»Run**.



The output of the op-amp appears on the scope.

7. Adjust the **Timebase** to 2 ms/Div and Channel A's **Scale** to 500 mV/Div.

The following displays on the oscilloscope:

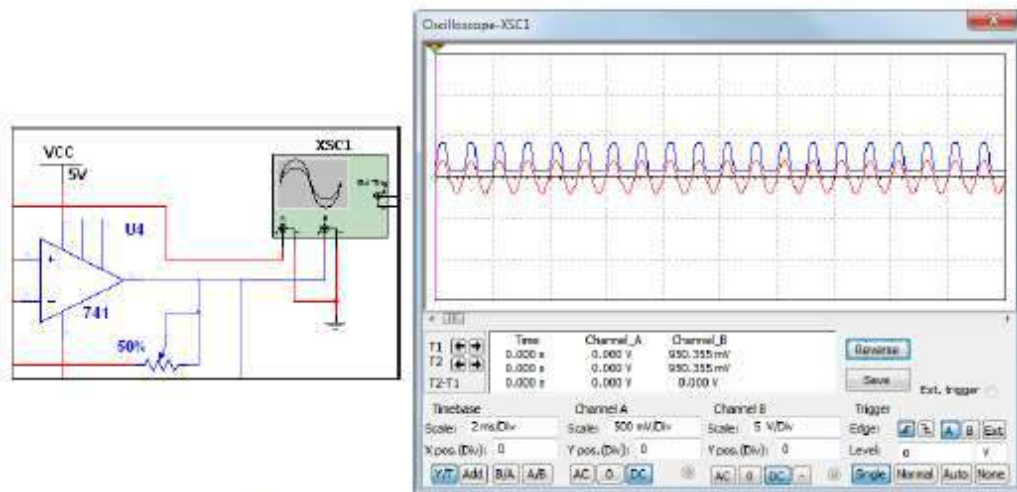

As the design simulates, the 7-segment display counts up and the LED flashes at the end of each count cycle.

8. Do the following:
 - a. Press <E> while the simulation is running to enable or disable the counter. Enable is Active Low.
 - b. Press <L> to load zeros into the counter. Load is Active Low.
 - c. Press <Shift-A> to observe the effect of decreasing the potentiometer's setting. Repeat, pressing <A> to increase.

3. Finish wiring the Digital Counter section as shown below.

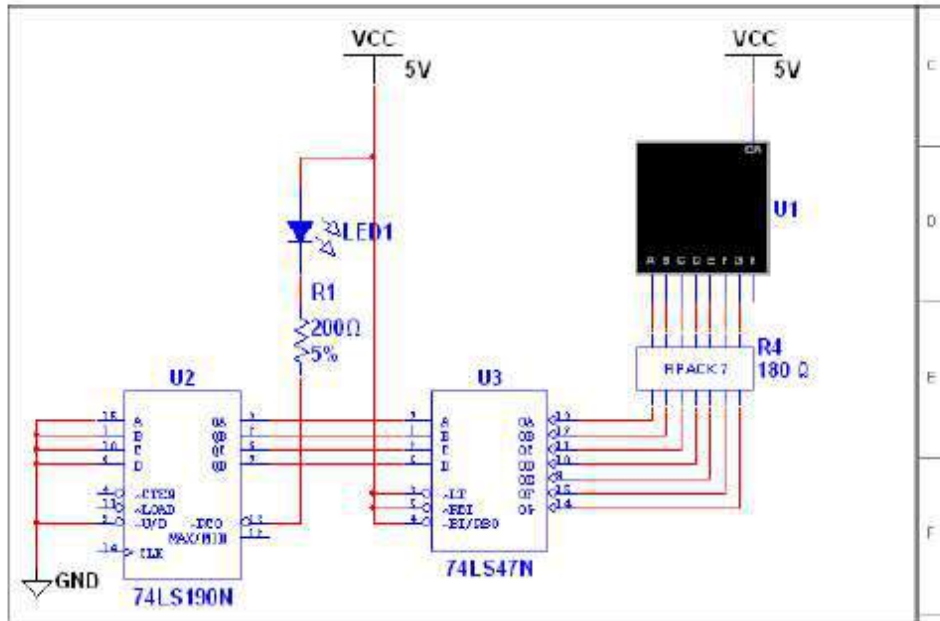

Tip Use **Bus Vector Connect** to wire multi-pinned devices like U3 and R4 together in a bus. Refer to the *Multisim Help* for details.



Tip **Virtual Wiring**—To avoid clutter, you can use virtual connections between the Counter Control and Digital Counter sections using on-page connectors. Refer to the *Multisim Help* for details.